



**Medtronic**

# Prostiva<sup>®</sup> RF Therapy

# 8930

Model 8930 Radio Frequency Generator

Model 8929 Hand Piece Kit

Model 8099 Telescope

! USA Model 8099TU15 Telescope

## System User Guide

! USA Rx Only



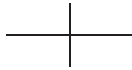
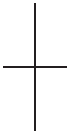

## Explanation of symbols on package labeling

Refer to the package label and radio frequency generator to see which symbols apply.



Conformité Européenne (European Conformity). This symbol means that the device fully complies with European Directive MDD 93/42/EEC.



Caution, consult accompanying documents



Consult instructions for use



Use by



Lot number



Serial number



Product number



Quantity



Non-sterile



Sterilized using irradiation



Sterilized using ethylene oxide



Do not resterilize



Do not reuse



For U.S. audiences only



Date of manufacture



Manufacturer



Authorized representative in the European community



Temperature limitation



Fragile



Keep dry



This way up



Stack height

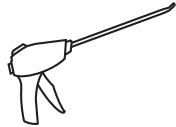

Hand piece connector port



Return electrode connector port



Foot switch connector port



Neutral electrode isolated from earth high frequency



Equipotential ground



Non-ionizing electromagnetic radiation



Universal Serial Bus (USB) port connector

ETL CLASSIFIED



This device conforms to UL STD 60601-1; certified to CSA STD C22.2 No. 601.1.



Danger: Explosion risk if used with flammable anesthetics



Fuse marking: Replace fuses as marked



IEC 60601-1/EN60601-1, Type BF equipment



OFF (AC Power)



ON (AC power)



Do not dispose of this product in the unsorted municipal waste stream. Dispose of this product according to local regulations. See <http://recycling.medtronic.com> for instructions on proper disposal of this product.



Note

The serial number format on the label is as follows:

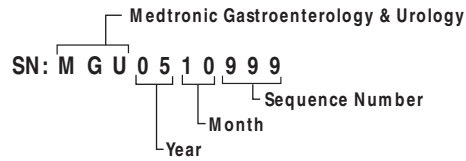

Medtronic®, Prostiva®, and TUNA® are trademarks of Medtronic, Inc. registered in the US. and other countries.

ACMI® is a registered trademark of American Cystoscope Makers, Inc.

Circon® is a registered trademark of Circon Corp.

Olympus® is a registered trademark of Olympus Corp.

Storz® is a registered trademark of Bausch and Lomb, Inc.

# Table of Contents

How to Use this Guide	ix
<b>1 Overview of the Prostiva Therapy System</b>	<b>13</b>
Introduction to Prostiva RF Therapy	14
Indications	14
Warnings	14
System Description	15
Accessories	17
<b>2 Radio Frequency Generator Description</b>	<b>25</b>
Components	26
User Interface	33
<b>3 Radio Frequency Generator Getting Started</b>	<b>55</b>
Getting Started	56
<b>4 Prostiva RF Therapy Procedure</b>	<b>63</b>
Patient Assessment	64
Patient and Hand Piece Preparation	68
Patient Treatment	74
<b>5 TUNA Therapy Clinical Overview</b>	<b>85</b>
Overview	86
<b>6 Specifications</b>	<b>95</b>
Device Specifications	96
<b>7 Supplemental Information</b>	<b>105</b>
Prostiva RF Therapy Worksheet	106
Periodic Inspection and Maintenance	109
Troubleshooting Checklist	112
<b>8 Device Warranties and End User License Agreement</b>	<b>117</b>
Device Warranties	118
End User License Agreement	124



## How to Use this Guide

This guide presents information for users of the Model 8930 Radio Frequency Generator. It contains information about the following:

- **Overview**

This chapter is a brief overview of the Radio Frequency Generator and the accessories that compose the Prostiva RF Therapy system.

- **Description**

This chapter identifies and describes the radio frequency generator case, controls, connectors, touch-screen information fields, and touch-screen interactive fields.

- **Getting Started**

This chapter provides the initial instruction required to setup and start the radio frequency generator.

- **Therapy Procedure**

This chapter provides instructions for preparing the patient, setting up the radio frequency generator system, and treating the patient.

- **Therapy Clinical Overview**

This chapter provides an overview of the Prostiva RF Therapy clinical information and includes the indications, contraindications, warnings, and precautions.

- **Specifications**

This chapter provides a list of general device specifications for reference. The information provided is nominal and approximate.

- **Supplemental Information**

This chapter provides a list of general reference information. This includes a therapy checklist, maintenance, and troubleshooting.

- **Warranties**

This chapter describes the device warranties. They apply only in the United States. Areas outside the United States should contact their local Medtronic representative for exact terms of the Limited Warranty.

x



# Overview of the Prostiva Therapy System

# 1

**This chapter provides a brief overview of the Prostiva RF Therapy system.**

**Introduction to Prostiva RF Therapy 14**

**Indications 14**

**Warnings 14**

**System Description 15**

**Accessories 17**

Hand Piece 17

Telescope 19

Tubing System 20

Return Electrode (neutral electrode) 22

Remote Foot Switch 23

User Supplied Materials 24

14 | **Chapter 1**  
Introduction to Prostiva RF Therapy

## Introduction to Prostiva RF Therapy

The Medtronic Prostiva RF Therapy is a minimally invasive treatment for patients with lower urinary tract symptoms due to benign prostatic hyperplasia (BPH). The Medtronic Prostiva RF System uses precisely focused radio frequency energy to ablate prostate tissue, which helps to reduce the constriction of the urethra and relieve BPH voiding symptoms.

The Medtronic Prostiva RF Therapy is clinically equivalent to the Medtronic TUNA (Transurethral Needle Ablation) Therapy. The Medtronic Prostiva RF Therapy and System represent a new version of the radio frequency generator and hand piece that are used for the same transurethral needle ablation procedure for treating benign prostatic hyperplasia.

## Indications

The Prostiva RF System is indicated for the treatment of symptoms due to urinary outflow obstruction secondary to benign prostatic hyperplasia (BPH) in men over the age of 50 with prostate sizes between 20 and 50 cm<sup>3</sup>.

## Warnings

Refer to Chapter 5, "TUNA Therapy Clinical Overview" on page 85 for a complete list of the contraindications, warnings, precautions, and clinical study information.

Read all warnings, precautions, and instructions for use carefully prior to use.

**⚠ Warning:** Do not use the Medtronic Prostiva RF System without reading all warnings, precautions, and instructions for use carefully prior to use. **Failure to read and follow all instructions, or failure to observe all stated warnings, could cause serious injury or death to the patient.**

Overview of the Prostiva Therapy System | 15  
System Description

**⚠ Warning:** The Prostiva RF therapy introduces needle perforations into organs or structures within the therapeutic prostate region which may result in fistulas within those organs or surrounding structures and could lead to serious health events for the patient.

## System Description

The Medtronic Prostiva RF Model 8930 Radio Frequency Generator (Figure 1-1) provides radio frequency energy through two output channels.



**Figure 1-1.** Model 8930 Radio Frequency Generator

The radio frequency generator system has three basic electronic functions:

**Radio frequency energy generation** – The radio frequency generator supplies the required power output (0 to 15 watts) to the attached treatment device (eg, hand piece).

**Power output control** – The generator software, by means of a closed-loop control circuit, continuously processes both temperature (°C) and impedance (Ohms) inputs to regulate the radio frequency power (watts) output of the generator. Power output is monitored throughout the procedure and is communicated via the RF generator display panel.

16 | **Chapter 1**  
System Description

**Sensor measurement** – Lesion temperature is measured by thermocouples located within each needle and urethral temperature is measured by thermocouples located within the hand piece tip. Impedance is measured from the generator, through the hand piece and targeted tissue, and back to the generator via the return electrode. The sensor measurements are displayed by the RF generator display screen.

### Generator case

The high-impact plastic generator case has a convenient carrying handle and a flip-open display screen. An easy-to-use latch mechanism secures and releases the flip-open display screen. The display screen provides clinicians with real-time treatment information in graphical and digital formats. Message fields on the display screen also provide critical information during the treatment procedure.

See Table 6-1 “Model 8930 Radio Frequency Generator Specifications” on page 96 for limitations of proper device operation.

### User interface

The user interface includes a touch-screen that responds to gloved and ungloved touch. When the clinician touches a control-button icon on the screen, the system performs the function selected if no errors exist.

The user interface also provides unique audible tones to automatically notify the clinician of the treatment status or alert condition.

### Data Storage

Detailed data for all lesions created during each patient session are collected and stored for review. The measurements for power, impedance, and temperature (for the left and right needles and for the urethra) are logged at intervals of 500ms and stored in an array during each lesion.

The information for up to 64 patient sessions is stored in a rolling buffer. After 64 sessions are saved, the oldest session record will be deleted as new sessions are recorded. The saved data is not affected by turning the generator off or by any other loss of generator power.

## Accessories

Only the following listed accessories are compatible for use with the Model 8930 RF Generator.

### Hand Piece

The Model 8929 Hand Piece (Figure 1-2) has the system radio frequency cable with an on/off switch and the irrigation tubing stopcock attached. The radio frequency cable and the tubing stopcock are clustered at the hand piece's proximal end.

Refer to the *Prostiva RF Therapy Kit Model 8929 Instructions for Use* for a detailed description of the hand piece.

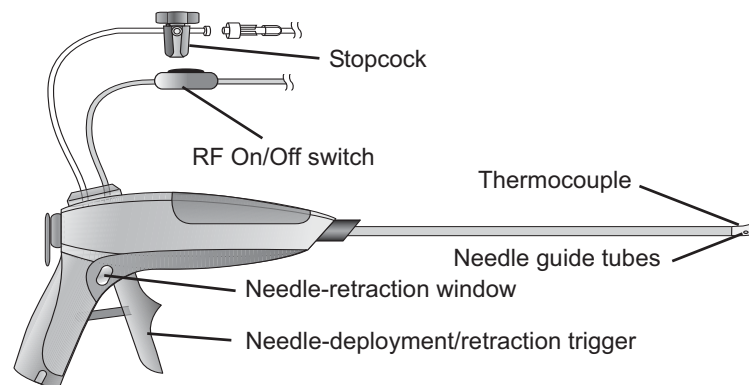

**Figure 1-2.** Model 8929 Hand Piece

At the distal end of the hand piece sheath, there is a bullet tip that facilitates sheath passage. A stationary thermocouple in the tip monitors the urethral temperature. Adjacent to the thermocouple are two small guide tubes through which the right and left lobe needles are deployed. Two other thermocouples, one in each needle tip, monitor the prostate temperature. The irrigation port at the needle deployment site provides fluid flow through the tubing system if tissue cooling or better visualization are needed.

The six-position selector dial on the handle's left side, allows the clinician to choose one of six preset needle penetration depths for treating the prostate. At the front of the handle, the needle-deployment/retraction trigger allows the clinician to respectively deploy and retract the shields and needles.

18 | **Chapter 1**  
Accessories

The radio frequency energy on/off switch is a press-and-release control. It is not necessary to hold the push button down to turn the energy output either on or off. Simply press the switch and then release it.

## Overview of the Prostiva Therapy System Accessories

19

The Model 8929 Hand Piece is supplied in a kit that includes the Model 6101 Tubing System and the Model 8934 Return Electrode.

The hand piece and its attachments are supplied as a sterile medical device. It is single-use-only, and after use it should be disposed of in accordance with local environmental requirements.

If the generator software detects a previously used hand piece, it automatically disables the radio frequency energy output so the device cannot be used for ablation. The software also displays an alert message on the display screen that notifies the user about this condition.

**Caution:** The Model 8929 Hand Piece is intended for single-use only. Do not attempt to reuse this ablation device. Attempting to resterilize the hand piece may cause damage to the device rendering it unsafe for further use. Multiple uses can result in the occlusion of the irrigation and needle openings, which can affect the device's performance.

See Table 6-2 "Model 8929 Hand Piece Specifications" on page 99 for limitations of proper device operation.

### Telescope

The Model 8099 Telescope is used with the Model 8929 Hand Piece to provide endoscopic visualization during the Prostiva RF Procedure. The telescope consists of an ocular sense assembly with a 0° angle of view, and a fiber-optic light cable connector. **The telescope must be clean and sterilized before each use.**

**USA** The Model 8099TU15 telescope is used with the Model 8929 Hand Piece to provide endoscopic visualization during the Prostiva RF Procedure. The telescope consists of an ocular sense assembly with a 15° angle of view, and a fiber-optic light cable connector. **The telescope must be clean and sterilized before each use.**

Refer to the appropriate telescope *Instructions for Use* for a detailed description of the telescope handling, cleaning, and sterilization. Additional information is included in the *Prostiva RF Therapy Kit Model 8929 Instructions for Use*.

On the hand piece, there is a telescope slot assembly that secures the telescope in position. This assembly also moves 1-2 cm to provide repositioning of the telescope to adjust the view.

20 | **Chapter 1**  
Accessories

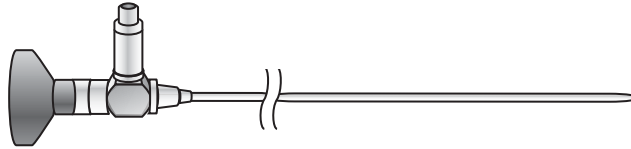
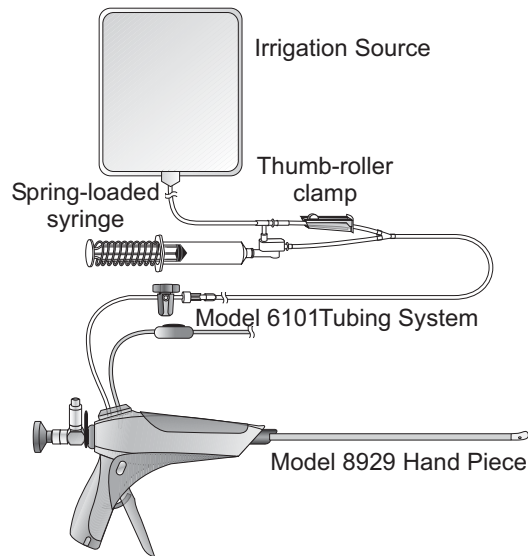

**Figure 1-3.** Telescope

The telescope is supplied as a non-sterile medical device. It is reusable and must be cleaned, sterilized, and used in accordance with the applicable instructions for use.

### Tubing System

The Model 6101 Tubing System connects to the Model 8929 Hand Piece to supply cooling fluid during the Prostiva RF Therapy procedure (Figure 1-4). This system connects to an irrigation source. The system helps provide clear visualization and any required cooling of the urethra. If the urethra temperature reaches 43° C, a caution message to start irrigation appears on the screen. If the urethra temperature reaches 47° C, the lesion automatically stops, and an alert message appears on the screen.



**Figure 1-4.** Model 8929 Hand Piece with Model 6101 Tubing System

**Overview of the Prostiva Therapy System** | 21  
Accessories

Refer to the *Prostiva RF Therapy Kit Model 8929 Instructions for Use* for a detailed description of the tubing system connecting, purging, and irrigating.

The sterile, single-channel tubing system connects to the two-way stopcock attached to the hand piece. The tubing system can be operated with either constant or hand-controlled irrigation. For hand-controlled irrigation, a spring-loaded 10-cm<sup>3</sup> (cc) syringe provides automatic filling. Closing the thumb-roller clamp and operating the syringe provides the hand-controlled irrigation. Opening the thumb-roller clamp provides constant irrigation. The two-way stopcock can also be set for aspiration when connected to an appropriate vacuum source.

The tubing system is supplied as a sterile medical product. It is single-use only, and it should be disposed of in accordance with local environmental requirements.

The Model 6101 Tubing System is supplied in the kit that includes the Model 8929 Hand Piece and the Model 8934 Return Electrode.

## Return Electrode (neutral electrode)

The Model 8934 Return Electrode (Figure 1-5) is placed on the patient's lower back and connects to the Model 8930 RF Generator. This connection completes the radio frequency ablation circuit with the Model 8929 Hand Piece.

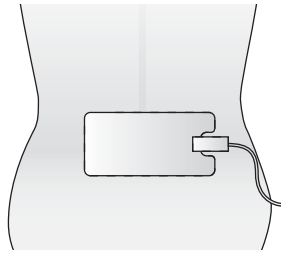

Figure 1-5. Model 8934 Return Electrode

Refer to the *Prostiva RF Therapy Kit Model 8929 Instructions for Use* for a detailed description of the return electrode applying, connecting, and removing.

The return electrode has a self-adhesive surface that secures it to the patient's skin. The return electrode provides a relatively large electrode area. This helps to reduce the density of the return-current flow from the hand piece to the patient's skin.

The return electrode also has a split-electrode design, which is required for the radio frequency generator's "neutral-electrode monitoring" (NEM) circuit. The NEM circuit monitors the impedance between the electrode halves. This provides a measure of how secure the electrode is attached to the patient's skin. The return electrode's design and monitoring help to reduce the risk of possible patient injury.

**Warning:** Do not use any return electrodes other than the Medtronic Model 8934. Use of other return electrodes may result in less than optimum system operation, or possible severe patient injury.

The Model 8934 Return Electrode is supplied in the kit that includes the Model 8929 Hand Piece and the Model 6101 Tubing System.

The return electrode is provided as a non-sterile medical device. It is single-use only, and it should be disposed of in accordance with local environmental requirements.

See Table 6-4 “Model 8934 Return Electrode” on page 100 for limitations of proper device operation.

### Remote Foot Switch

The Model 60883 Remote Foot Switch (Figure 1-6) is an optional remote control device that connects to the rear panel of the Model 8930 Radio Frequency Generator (Figure 2-6). It operates in parallel with the Model 8929 Hand Piece on/off switch. When the radio frequency generator is in a “System ready” condition and the remote foot switch is properly connected to the generator, the clinician can press and release the foot switch to start radio frequency treatment. To stop the radio frequency treatment, the clinician presses and releases the remote foot switch; the treatment stops as soon as the clinician presses the switch.

The connector end of the remote foot switch has an easy-to-use connector release mechanism. To disconnect the cable from the generator, pull straight out on the connector to disengage it.

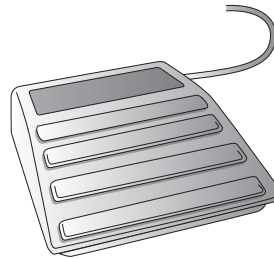

**Figure 1-6.** Model 60883 Remote Foot Switch

24 | **Chapter 1**  
Accessories

**User Supplied Materials**

Other materials that are typically required for the Prostiva RF Procedure include, but are not limited to, the following items:

- Xylocaine hydrochloride liquid and gel anesthetic or similar agent
- Water soluble lubricant
- Light source and light cord
- Irrigation solution with irrigation tubing and stopcock
- Aspiration tubing and vacuum source
- Penile clamp
- Olympus adapters
- Catheters
- Leg bag
- Prep tray
- Betadine
- Patient drapes
- Surgical attire
- Optional video camera and display

# Radio Frequency Generator Description

## 2

**This chapter identifies and describes the radio frequency generator case, controls, connectors, touch-screen information fields, and touch-screen interactive fields.**

### **Components 26**

- Introduction 26
- Display Screen 28
- Therapy Connector Panel 28
- Therapy Connector Panel Icons 29
- Left-Side Panel 30
- Back Panel 31

### **User Interface 33**

- Introduction 33
- Display Screen 33
- Digital Readout Icons and Symbols 35
- Control Buttons 37
- Operating Messages 39

## Components

### Introduction

The Model 8930 Radio Frequency Generator (Figure 2-1) is lightweight and portable with state-of-the-art electronics and design features that provide the clinician with a safe and effective Prostiva RF Therapy system. The following are the basic user components:

- Flip-open display screen
- Flip-open push button
- Radio frequency energy: blue light-emitting diodes (LEDs)
- AC power: green LED
- Left-side: Universal Serial Bus (USB) port<sup>1</sup>
- Right-side: therapy connector panel
- Back panel: AC power control, optional foot switch connector, USB port<sup>1</sup>, ground terminal, and cooling fan

At the top of the cover assembly, there is a bezel light panel with three light-emitting diodes (LEDs): two blue and one green. When the center green LED is lit, it indicates that the AC power is on. When the two blue LEDs are flashing, the generator software is checking that the system configuration is ready for a lesion to be started. When the blue LEDs are on solid, a lesion is in progress.

<sup>1</sup> Not used for Prostiva RF Therapy; security protected for Medtronic use only

Radio Frequency Generator Description | 27  
Components

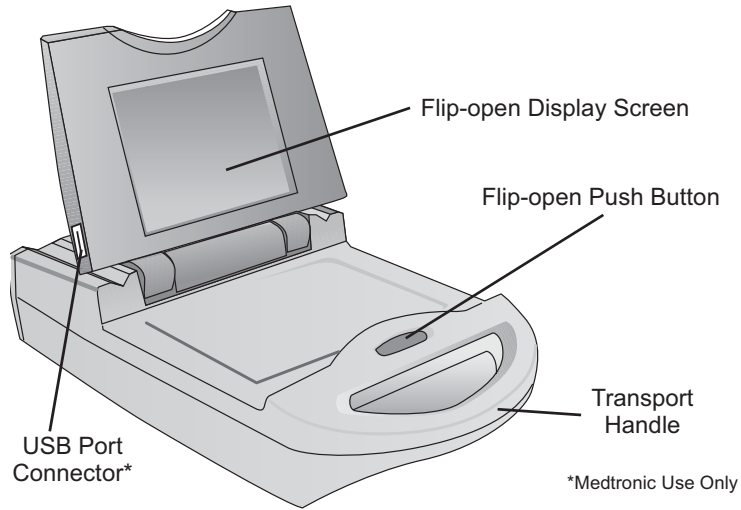

Figure 2-1. Model 8930 Radio Frequency Generator Case

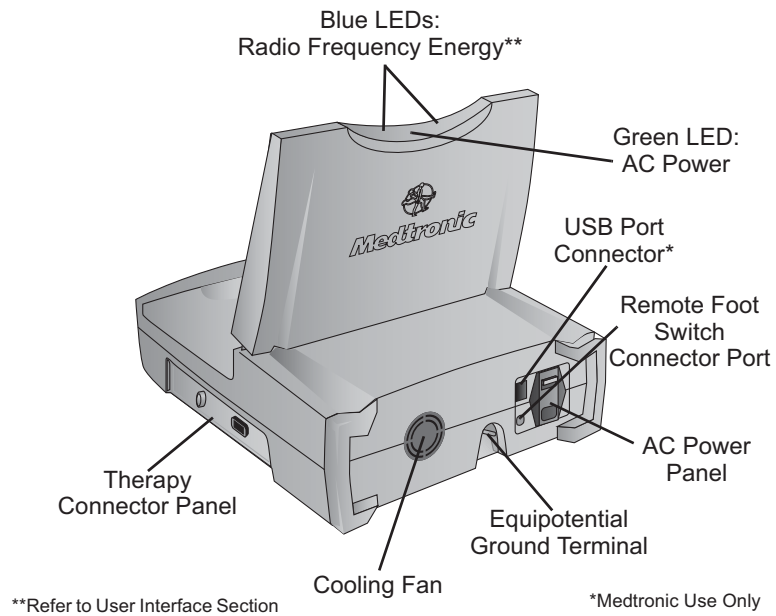

Figure 2-2. Model 8930 Radio Frequency Generator: Connectors, Controls, and Indicator Lights (LEDs)

## Display Screen

The color (640x480 pixels), liquid-crystal-display (LCD) screen closes into the case for storage and flips open on a hinge for use (Figure 2-3). The display screen provides clinicians with real-time treatment information in graphical and digital formats. The screen's hinge allows adjustment for different viewing angles. When the radio frequency generator is on, the screen also remains on at all times and in all positions; there is no "screen saver" mode.

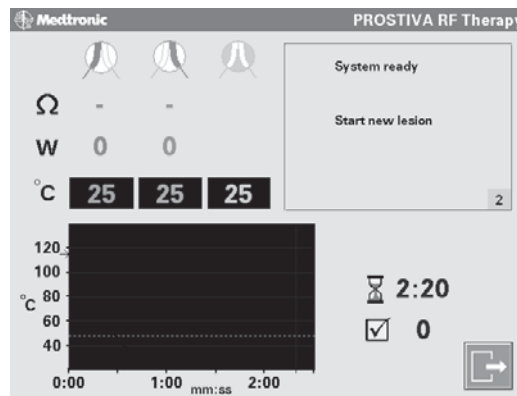

Figure 2-3. Display Screen Application Window

## Therapy Connector Panel

The therapy connector panel (Figure 2-4) contains two connectors for the radio frequency therapy delivery system components. The sterile Model 8929 Hand Piece cable plugs into the circular connector, and the non-sterile Model 8934 Return Electrode plugs into the rectangular connector.<sup>1</sup>

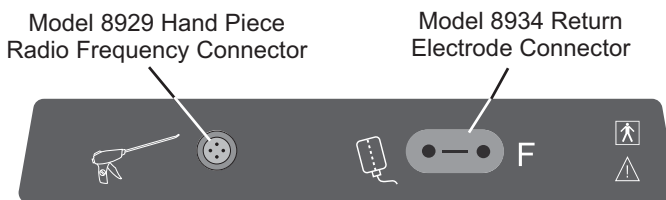

Figure 2-4. Model 8930 Therapy Connector Panel



<sup>1</sup> The model 8930 RF Generator is not intended to be connected to, or used with, the Model 1900 Hand Piece. Do not attempt to connect or use these two devices together.

**Radio Frequency Generator Description** | 29  
**Components**

The following table describes the function of the connectors on the panel.

**Therapy Connector Panel Icons**

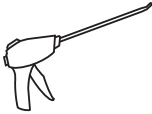
**Table 2-1.** Therapy Connector Panel Icons

Icon	Description	Function
	<p><b>Model 8929 Hand Piece Connector</b></p>	<ul style="list-style-type: none"> <li>▪ Connects to the hand piece radio frequency cable that has a locking connector</li> <li>▪ Provides electrical path for radio frequency energy and monitoring signals</li> </ul>
	<p><b>Model 8934 Return Electrode Connector</b></p>	<ul style="list-style-type: none"> <li>▪ Connects to the patient return electrode</li> <li>▪ Completes electrical path for radio frequency energy and monitoring signals</li> </ul>
<p><b>F</b></p>	<p><b>Return Electrode Function Symbol</b></p>	<ul style="list-style-type: none"> <li>▪ Neutral electrode isolated from earth high frequency</li> </ul>
	<p><b>Type BF Symbol</b></p>	<ul style="list-style-type: none"> <li>▪ Type BF equipment</li> <li>▪ Protected against electrical shock per IEC 60601-1</li> </ul>

### Left-Side Panel

On the left-side panel there is a Universal Serial Bus (USB) port connector (Figure 2-5), which is intended for **Medtronic field service personnel only**. It allows Medtronic field service personnel to connect a USB flash-memory device to the radio frequency generator. The flash-memory device can be used for uploading application updates and for downloading stored system data from the generator. This is for system diagnostic and utilization data purposes only. It is not used for the Prostiva RF Therapy, and it is secured against unauthorized use.

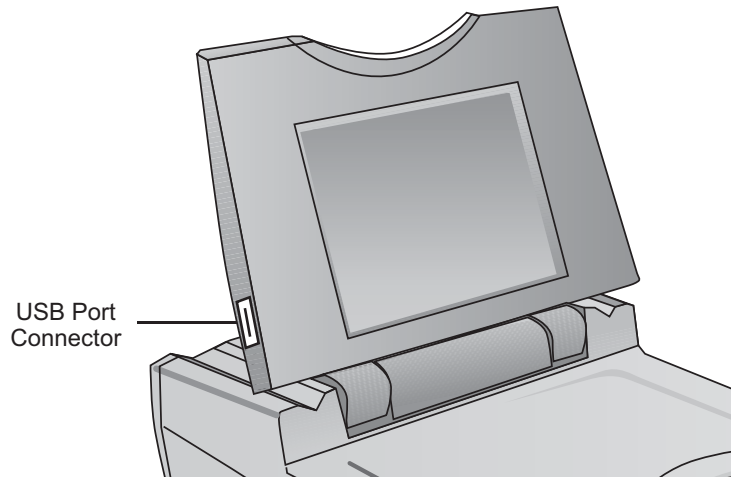

**Figure 2-5.** Model 8930 Left-side Panel USB Port Connector

## Back Panel

The back panel (Figure 2-6) contains the AC power, equipotential ground, and optional device connections (see Table 2-2 on page 32). The AC power connection includes a power-entry plug assembly with an ON-OFF power switch and two power fuses. A recessed, equipotential grounding terminal provides convenient access for grounding the generator with another electronic device. There is also a connector for the cable to the optional Medtronic foot switch Model 60883 that actuates the radio frequency delivery system. The back panel USB communications port is for **Medtronic field service personnel only**. The port is secured against unauthorized use.

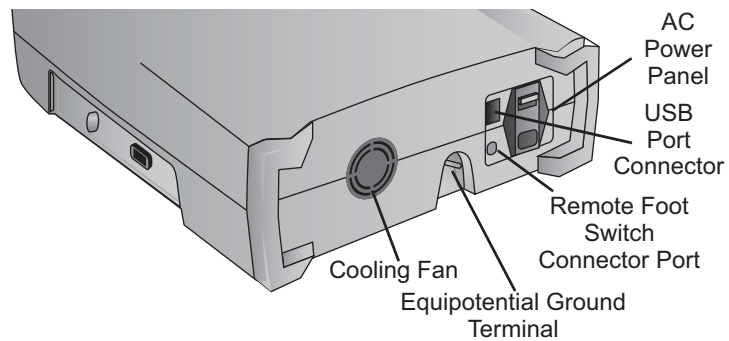
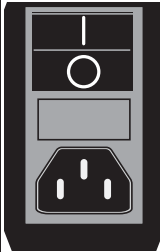





Figure 2-6. Model 8930 Back Panel

32 | Chapter 2  
 Components

The following table (Table 2-2) describes the function of the connectors on the back panel.

**Table 2-2.** Back Panel Components

Reference	Name	Description
	<b>AC Power Panel:</b> <b>Power Switch</b> <b>Fuse Compartment</b> <b>Power Connector</b>	<ul style="list-style-type: none"> <li>Turns ON (I) and OFF (O) AC power to generator</li> <li>Provides access to input power fuses</li> <li>Input connection through power cord to AC power outlet</li> </ul>
	<b>USB Port Connector</b>	<ul style="list-style-type: none"> <li>Connection to USB cable for external digital device communication. This security-protected connector is not used for Prostiva RF Therapy, and is for Medtronic use only.</li> </ul>
	<b>Foot Switch Connector</b>	<ul style="list-style-type: none"> <li>Input connection for the optional external foot switch for radio frequency power ON and OFF</li> </ul>
	<b>Cooling Fan</b>	<ul style="list-style-type: none"> <li>Provides constant air flow to cool electronics when power is on</li> </ul>
	<b>Equipotential Ground Terminal</b>	<ul style="list-style-type: none"> <li>Provides common electrical ground for other electronic devices being used during the procedure</li> </ul>

## User Interface

### Introduction

This section describes the operation of the hardware and software components. These components provide you with the information and the control of the Prostiva RF Therapy Generator. The generator consists of three main components: hardware, core software, and application software. The flexibility of the hardware and the core software enables Medtronic to provide future updates to the Prostiva RF Therapy.

The features of application software for the Prostiva RF Therapy are outlined in this section.

### Display Screen

Liquid Crystal Display (LCD) 640 x 480 pixels of 16-bit color with a touch screen overlay for user input. The overlay is designed for use with or without surgical gloves. There is no keyboard or mouse, so user inputs are made through the touch control buttons on the display screen.

The display screen window (Figure 2-7) can be classified into four information and control areas:

- Lesion digital and graphic readouts (color coded)
- Operating messages
- Lesion time and count
- Control buttons

The digital and graphic readouts for temperature are respectively color coded as follows:

- Left needle-green
- Right needle-red
- Urethra-aqua

The needle impedance ( $\Omega$ ) and power (W) digital readouts follow this same color coding.

34 | Chapter 2  
User Interface

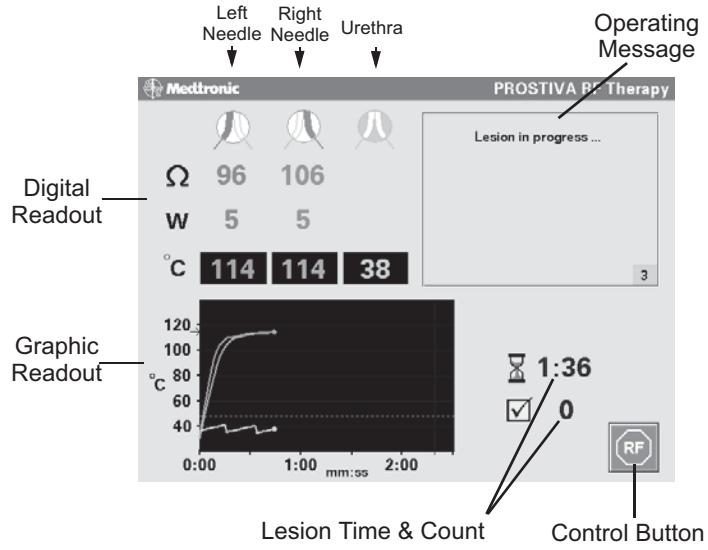





Figure 2-7. Display Screen Information and Control Areas





### Digital Readout Icons and Symbols

There are several display screen icons and symbols that identify data display readouts and controls. The following tables describe each of these. The first three icons in the table are representations of the clinician's view of the needles through the telescope.

**Table 2-3.** Display Screen Icons and Symbols

Icon/Symbol	Name	Description
	<b>Left Needle Lesion</b>	<ul style="list-style-type: none"> <li>Column heading icon for left needle (green) impedance, power, and temperature readouts</li> </ul>
	<b>Right Needle Lesion</b>	<ul style="list-style-type: none"> <li>Column heading icon for right needle (red) impedance, power, and temperature readouts</li> </ul>
	<b>Urethra Temperature</b>	<ul style="list-style-type: none"> <li>Column heading icon for urethra temperature (aqua) readout</li> </ul>
<b>°C</b>	<b>Centigrade</b>	<ul style="list-style-type: none"> <li>Units symbol for measured needle and urethra temperature readout</li> </ul>
<b>Ω</b>	<b>Ohms</b>	<ul style="list-style-type: none"> <li>Units symbol for measured needle impedance readout</li> </ul>
<b>W</b>	<b>Watts</b>	<ul style="list-style-type: none"> <li>Units symbol for closed-loop, computer controlled radio-frequency output power readout</li> </ul>

**Table 2-3.** Display Screen Icons and Symbols (continued)





Icon/Symbol	Name	Description
	<b>Lesion Time Remaining</b>	<ul style="list-style-type: none"><li>▪ Icon for remaining time countdown readout from 2:20 to 0:00 for lesion</li></ul>
	<b>Good Lesion Count</b>	<ul style="list-style-type: none"><li>▪ Icon for lesion count readout that displays number of successful lesions since current patient session start</li></ul>
	<b>Alert Message</b>	<ul style="list-style-type: none"><li>▪ Red symbol for alert message readout</li></ul>
	<b>Caution Message</b>	<ul style="list-style-type: none"><li>▪ Yellow symbol for caution message readout</li></ul>
	<b>Speaker Volume Level</b>	<ul style="list-style-type: none"><li>▪ Speaker volume level icon readout for volume control icon; number of curved lines increases and decreases with volume setting; there are five volume levels; the lowest level is still audible; there is <b>no off setting</b></li></ul>

**Radio Frequency Generator Description** | 37  
 User Interface

**Control Buttons**



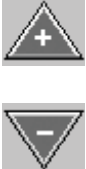

The following table (Table 2-4) lists the active control buttons that display on the various screens. The control buttons are color-coded in blue. These control button icons are the only touch-activated areas on the screen display. No other areas of the display screen window are touch-activated.

**Table 2-4.** Display Screen Buttons

Button	Name	Description
	<p><b>Therapy Selection</b></p>	<ul style="list-style-type: none"> <li>▪ Selects Prostiva RF Therapy by advancing to the initial therapy screen</li> </ul>
	<p><b>Language Selection</b></p>	<ul style="list-style-type: none"> <li>▪ Selects language option for the Prostiva RF Therapy screens. Options include English, French, German, and Greek</li> </ul>
	<p><b>Increase +</b>  <b>and</b>  <b>Decrease -</b>  <b>Volume Control</b></p>	<ul style="list-style-type: none"> <li>▪ Volume control buttons to set speaker volume for alarm tones; there are five speaker volume levels, and the lowest level setting remains audible; there is <b>no off setting</b></li> </ul>
	<p><b>Stop Radio Frequency Output</b></p>	<ul style="list-style-type: none"> <li>▪ Press to turn off radio frequency energy and stop the current lesion; this does not end the session</li> </ul>

38 | **Chapter 2**  
User Interface

**Table 2-4.** Display Screen Buttons (continued)

Button	Name	Description
	<b>Exit Therapy</b>	<ul style="list-style-type: none"><li>Press to exit the current therapy session and display the end session screen</li></ul>
	<b>Resume</b>	<ul style="list-style-type: none"><li>Press to return to the therapy screen and resume the current therapy session</li></ul>
	<b>New Patient</b>	<ul style="list-style-type: none"><li>Press to end this session and start a new patient session</li></ul>
	<b>Quit</b>	<ul style="list-style-type: none"><li>Press to quit the therapy session and transfer to the start-up screen</li></ul>

## Operating Messages

The system user interface provides text messages in an information window on the display screen, as well as concurrent audible alarms for almost all messages. The three basic types of operating messages are:

- Status message
- Alert message
- Caution message

For additional information on related probable causes and prevention of problems, see Table 7-1 on page 112.

## Audible Alarms

There are seven different audible alarms for various systems events. These alarms vary with the type of message and its content. The description of each alarm tone is explained in Table 2-5. For each of the system messages outlined in the following tables, the applicable alarm is included in the description.

**Table 2-5.** Alarm Tones

Alarm Name	Tone Description
Lesion Start	1 medium
Lesion in Progress	1 short beep repeated every 4 seconds
Lesion Complete	1 long beep
Lesion Abort	2 short beeps + 1 long beep
Urethra Temperature Caution	3 short beeps every 2 seconds
Single-Needle Alert	3 short beeps with varied tone for each
General Alert	2 short beeps

### Status Messages

Status messages appear in the operating message window of the screen display. For example, in Figure 2-8, the “System ready” messages appear in black on a light gray background. The message index number that appears in the lower right corner of the message window, corresponds to the same message index number in Table 2-6 on page 41.

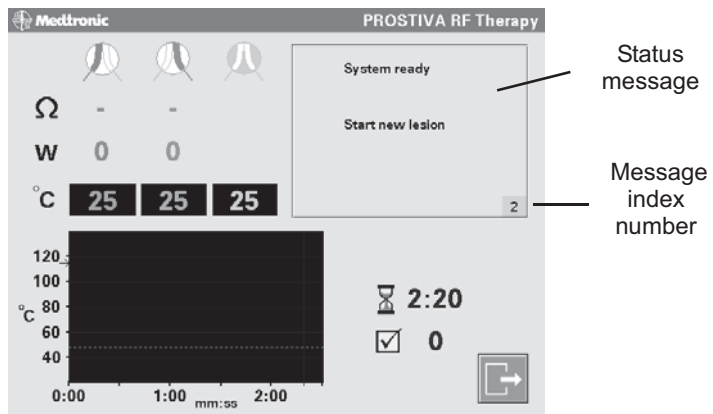

Figure 2-8. Status Message Display Example

Radio Frequency Generator Description | 41  
User Interface

Table 2-6. Status Messages

No.	Message	Explanation
1	<b>System test in progress...</b>	<ul style="list-style-type: none"><li>▪ Radio frequency generator system test of internal electronics and attached accessories (ie, hand piece, return electrode) is running</li><li>▪ Message stays on until system test is completed (approximately five seconds)</li><li>▪ <b>No alarm</b> occurs during system test</li></ul>
2	<b>System ready</b> <b>Start new lesion</b>	<ul style="list-style-type: none"><li>▪ Radio frequency generator and attached accessories (eg, hand piece, return electrode) are ready for use</li><li>▪ Message stays on until clinician starts radio frequency, or an alert occurs</li><li>▪ <b>No alarm</b> occurs during system ready</li><li>▪ Both blue LEDs flash continuously at a regular rate</li></ul>
3	<b>Lesion in progress....</b>	<ul style="list-style-type: none"><li>▪ Lesion treatment with both needles has started and is continuing</li><li>▪ Message stays on during lesion unless caution message displays</li><li>▪ "Lesion Start" alarm is <b>1 medium beep</b></li><li>▪ "Radio Frequency On" alarm is <b>1 short beep every 4 seconds</b></li><li>▪ Both blue LEDs are on solid</li></ul>

42 | Chapter 2  
User Interface

Table 2-6. Status Messages (continued)

No.	Message	Explanation
4	<b>Lesion in progress with left needle only...</b>	<ul style="list-style-type: none"><li>▪ Lesion treatment is with left needle only because right needle may be outside prostate and has shut off</li><li>▪ Message stays during lesion unless caution message displays</li><li>▪ Alarm is <b>1 short beep every 4 seconds</b></li><li>▪ Both blue LEDs are on solid</li></ul>
5	<b>Lesion in progress with right needle only...</b>	<ul style="list-style-type: none"><li>▪ Lesion treatment is with right needle only because left needle may be outside prostate and has shut off</li><li>▪ Message stays on during lesion unless caution message displays</li><li>▪ Alarm is <b>1 short beep every 4 seconds</b></li><li>▪ Both blue LEDs are on solid</li></ul>
6	<b>Lesion complete</b> <b>Retract and reposition needles</b> <b>Start new lesion</b>	<ul style="list-style-type: none"><li>▪ Lesion time of <b>2.3 minutes</b> has expired and system is ready to start next lesion</li><li>▪ Message stays on until clinician starts next lesion</li><li>▪ Alarm is <b>1 long beep</b></li><li>▪ Both blue LEDs flash at a continuous rate</li></ul>

### Alert Messages

An alert message occurs when the radio frequency generator detects a problem with the needle impedance, the urethral temperature, or the system equipment (ie, generator, hand piece, return electrode). **An alert message can appear on the screen either during a lesion, before a lesion, or after a lesion.** Alert messages also include the probable cause and the recommended corrective action.

**The selection of the appropriate corrective action is in the clinician's sole medical judgement.**

**If an alert condition occurs with the radio frequency energy on, the alert automatically stops the lesion.** It turns off the radio frequency energy output to both channels. The simultaneous lesion abort and alert message comprises the system's safety shutdown feature (see: "Safety Shutdown Conditions" on page 60).

All system alert messages require some corrective action by the clinician.

Some alert messages stay on the LCD screen until the clinician clears the causing condition, while other messages will clear from the screen in five to ten seconds.

There are also audible alarms for each message, which vary with the type of message. The occurrence and duration of the alarm tones and messages are explained in Table 2-7 on page 44.

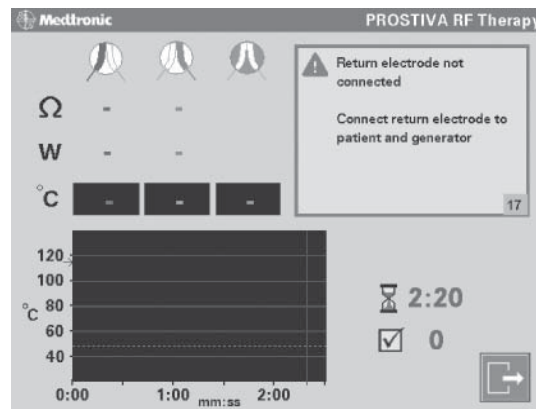

Figure 2-9. Alert Message Display Example

Table 2-7. Alert Messages

No.	Message	Explanation
11	<b>Generator problem</b>  <b>Restart generator</b>  <b>Contact Medtronic if problem persists</b>	<ul style="list-style-type: none"> <li>▪ Radio frequency generator has a hardware or software problem that may be recoverable</li> <li>▪ Problem may be correctable if user restarts system</li> <li>▪ Message shows briefly until system displays a solid blue screen; this may clear when system is restarted</li> <li>▪ Alarm is <b>2 short beeps + 1 long beep</b> if radio frequency <b>on</b>; if <b>off</b>, <b>2 short beeps</b></li> </ul>
12	<b>Generator overheated</b>  <b>Check air vents and wait 5 minutes before continuing</b>  <b>Contact Medtronic if problem persists</b>	<ul style="list-style-type: none"> <li>▪ Radio frequency generator is overheated</li> <li>▪ Check bottom vents and fan clearances; allow generator to cool for at least five minutes</li> <li>▪ Message stays on for five minutes until generator is cool enough to proceed</li> <li>▪ Alarm is <b>2 short beeps + 1 long beep</b> if radio frequency <b>on</b>; if <b>off</b>, <b>2 short beeps</b></li> </ul>
13	<b>Hand piece not connected</b>  <b>Connect hand piece to generator</b>	<ul style="list-style-type: none"> <li>▪ Hand piece cable is not properly connected to the radio frequency generator</li> <li>▪ Hand piece must be connected in order to proceed</li> <li>▪ Message stays on until user connects hand piece cable</li> <li>▪ Alarm is <b>2 short beeps + 1 long beep</b> if radio frequency <b>on</b>; if <b>off</b>, <b>2 short beeps</b></li> </ul>

**Radio Frequency Generator Description** | 45  
User Interface

**Table 2-7.** Alert Messages (continued)

No.	Message	Explanation
14	<b>Hand piece problem</b> <b>Replace hand piece</b>	<ul style="list-style-type: none"><li>▪ Hand piece is not properly functioning</li><li>▪ Hand piece must be replaced with new unit in order to proceed</li><li>▪ Message stays on until user replaces hand piece</li><li>▪ Alarm is <b>2 short beeps + 1 long beep</b> if radio frequency <b>on</b>; if <b>off</b>, <b>2 short beeps</b></li></ul>
15	<b>Usage limit reached</b> <b>Replace hand piece</b>	<ul style="list-style-type: none"><li>▪ Hand piece is at its maximum-use limit; it can no longer be used</li><li>▪ Hand piece must be replaced with new unit in order to proceed</li><li>▪ Message stays on until user replaces hand piece</li><li>▪ Alarm is <b>2 short beeps</b></li></ul>
16	<b>Hand piece switch problem</b> <b>Check hand piece switch or use foot switch</b>	<ul style="list-style-type: none"><li>▪ Hand piece switch is stuck, or kept pressed for more than five seconds</li><li>▪ Hand piece switch should be checked</li><li>▪ Message stays on until user takes corrective action or disconnects the hand piece</li><li>▪ Alarm is <b>2 short beeps + 1 long beep</b> if radio frequency <b>on</b>; if <b>off</b>, <b>2 short beeps</b></li></ul>

Table 2-7. Alert Messages (continued)

No.	Message	Explanation
17	<p><b>Return electrode not connected</b></p> <p><b>Connect return electrode to patient and generator</b></p>	<ul style="list-style-type: none"> <li>▪ Return electrode is not properly applied to the patient, or the cable is not connected to the radio frequency generator</li> <li>▪ Return electrode must be connected in order to proceed</li> <li>▪ Message stays on until user properly applies return electrode or connects cable</li> <li>▪ Alarm is <b>2 short beeps + 1 long beep</b> if radio frequency <b>on</b>; if <b>off</b>, <b>2 short beeps</b></li> </ul>
18	<p><b>Return electrode problem</b></p> <p><b>Replace with split return electrode supplied by Medtronic</b></p>	<ul style="list-style-type: none"> <li>▪ Return electrode being used is not compatible</li> <li>▪ Replace return electrode with Medtronic split-pad</li> <li>▪ Message stays on until user replaces return electrode</li> <li>▪ Alarm is <b>2 short beeps</b></li> </ul>
19	<p><b>Impedance problem</b></p> <p><b>Check hand piece and return electrode</b></p>	<ul style="list-style-type: none"> <li>▪ Radio frequency circuit is not complete, or has a problem (open &gt; 999 ohms; short &lt;35 ohms)</li> <li>▪ Check cable connections</li> <li>▪ Message stays until user corrects and impedance is no longer out of range; displays for a minimum of ten seconds</li> <li>▪ Alarm is <b>2 short beeps + 1 long beep</b> if radio frequency <b>on</b>; if <b>off</b>, <b>2 short beeps</b></li> </ul>

**Radio Frequency Generator Description** | 47  
 User Interface

**Table 2-7.** Alert Messages (continued)

No.	Message	Explanation
20	<b>Temperature problem</b>  <b>Check hand piece</b>  <b>Contact Medtronic if problem persists</b>	<ul style="list-style-type: none"> <li>▪ Temperature measurement from thermocouples is outside 0° C to 150° C range</li> <li>▪ Message clears when temperature is within range; displays for minimum of ten seconds</li> <li>▪ Alarm is <b>2 short beeps + 1 long beep</b> if radio frequency <b>on</b>; if <b>off</b>, <b>2 short beeps</b></li> </ul>
21	<b>Foot switch problem</b>  <b>Check foot switch or remove foot switch and use hand piece switch</b>	<ul style="list-style-type: none"> <li>▪ Optional foot switch is stuck, or kept pressed for more than five seconds</li> <li>▪ Foot switch should be checked, or replace with a new unit</li> <li>▪ Message stays on until foot switch is released or disconnected</li> <li>▪ Alarm is <b>2 short beeps + 1 long beep</b> if radio frequency <b>on</b>; if <b>off</b>, <b>2 short beeps</b></li> </ul>
25	<b>Lesion stopped by user</b>	<ul style="list-style-type: none"> <li>▪ The clinician has stopped radio frequency output before end of lesion</li> <li>▪ If system conditions OK, radio frequency generator will switch to "System ready" in approximately five seconds</li> <li>▪ Message stays on until system switches to "System ready"</li> <li>▪ Alarm is <b>2 short beeps + 1 long beep</b></li> </ul>

Table 2-7. Alert Messages (continued)

No.	Message	Explanation
31	<p><b>Needle impedance (<math>\Omega</math>) too high</b></p> <p><b>Retract needles, and reposition or reduce length</b></p> <p><b>Needle may be in dry or hard tissue, or outside prostate</b></p>	<ul style="list-style-type: none"> <li>▪ Impedance exceeds 600 ohms; <b>stops lesion</b></li> <li>▪ Needle position is not optimal, and it must be changed</li> <li>▪ Message stays on for ten seconds</li> <li>▪ Alarm is <b>2 short beeps + 1 long beep</b></li> </ul>
32	<p><b>Needle temperature too high</b></p>	<ul style="list-style-type: none"> <li>▪ Radio frequency delivery has raised needle temperature above <b>125° C</b>; <b>stops lesion</b></li> <li>▪ Message stays on for ten seconds</li> <li>▪ Alarm is <b>2 short beeps + 1 long beep</b></li> <li>▪ Needle position is not optimal, and it must be changed</li> </ul>
33	<p><b>Needle temperature too low</b></p> <p><b>Retract needles, and reposition or reduce length</b></p> <p><b>Needle may be near bladder or blood vessel, or outside prostate</b></p>	<ul style="list-style-type: none"> <li>▪ Needle may be incorrectly positioned in bladder; <b>stops lesion</b></li> <li>▪ Needle position or length is not optimal, and it must be changed</li> <li>▪ Message stays on for ten seconds</li> <li>▪ Alarm is <b>2 short beeps + 1 long beep</b></li> </ul>
34	<p><b>Urethra temperature too high</b></p>	<ul style="list-style-type: none"> <li>▪ Radio frequency delivery has raised urethral temperature above <b>47° C</b>; <b>stops lesion</b></li> <li>▪ Clinician must irrigate more frequently to help prevent the urethra from overheating</li> <li>▪ Message stays on for ten seconds</li> <li>▪ Alarm is <b>2 short beeps + 1 long beep</b></li> </ul>

### Caution Messages

A caution message (Figure 2-10) occurs when the radio frequency generator monitoring circuits detect an out-of-range condition with the needle impedance, the urethral temperature, or the needle temperature. **A caution message appears on the screen only during a lesion. It does not stop a lesion.**

Some caution messages also include the probable cause. Other messages contain recommended corrective action and continued treatment status.

**The selection of the appropriate corrective action or continued treatment is in the clinician's sole medical judgement.**

Certain caution conditions automatically turn **off** the radio frequency energy output for the affected needle. The caution message automatically clears from the screen in approximately five to ten seconds. Refer to Table 2-8 on page 50 for detailed information on the caution messages.

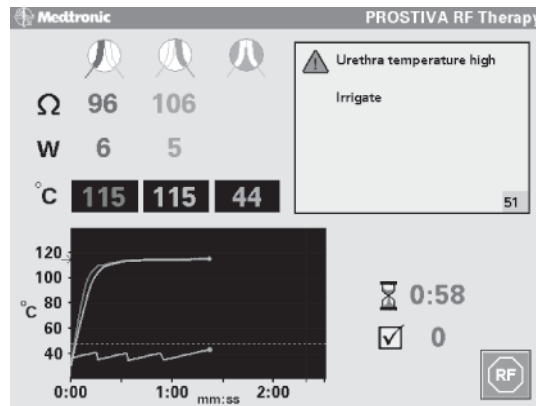

Figure 2-10. Caution Message Example

### Caution Messages

Table 2-8. Caution Messages

No.	Message	Explanation
51	<b>Urethra temperature high</b> <b>Irrigate</b>	<ul style="list-style-type: none"><li>▪ Urethra temperature exceeds <b>43° C</b> and must be irrigated with cool water to lower temperature</li><li>▪ Message stays on until temperature drops below <b>43° C</b></li><li>▪ Alarm is <b>3 short beeps repeated every 4 seconds</b></li><li>▪ If temperature reaches <b>47° C</b>, system <b>stops lesion</b> (see alert message 34, Table 2-7 on page 44)</li></ul>
52	<b>Left needle impedance (Ω) low</b>	<ul style="list-style-type: none"><li>▪ Occurs only at start of a lesion when left needle has impedance &lt; 80 ohms</li><li>▪ Nominal starting range is 80 to 180 ohms</li><li>▪ Physician may continue with lesion</li><li>▪ Message stays on for ten seconds</li><li>▪ Alarm is <b>2 short beeps</b></li></ul>
53	<b>Right needle impedance (Ω) low</b>	<ul style="list-style-type: none"><li>▪ Occurs only at start of a lesion when right needle has impedance &lt; 80 ohms</li><li>▪ Nominal starting range is 80 to 180 ohms</li><li>▪ Physician may continue with lesion</li><li>▪ Message stays on for ten seconds</li><li>▪ Alarm is <b>2 short beeps</b></li></ul>

**Radio Frequency Generator Description** | 51  
 User Interface

**Table 2-8.** Caution Messages (continued)

No.	Message	Explanation
54	<b>Needle impedance (<math>\Omega</math>) low</b>	<ul style="list-style-type: none"> <li>▪ Occurs only at start of a lesion when both needles have impedance &lt; 80 ohms</li> <li>▪ Nominal starting range is 80 to 180 ohms</li> <li>▪ Physician may continue with lesion</li> <li>▪ Message stays on for ten seconds</li> <li>▪ Alarm is <b>2 short beeps</b></li> </ul>
55	<b>Left needle impedance (<math>\Omega</math>) high</b>	<ul style="list-style-type: none"> <li>▪ Occurs only at start of a lesion when left needle has impedance &gt;180 ohms</li> <li>▪ Nominal starting range is 80 to 180 ohms</li> <li>▪ Physician may continue with lesion</li> <li>▪ Message stays on for ten seconds</li> <li>▪ Alarm is <b>2 short beeps</b></li> </ul>
56	<b>Right needle impedance (<math>\Omega</math>) high</b>	<ul style="list-style-type: none"> <li>▪ Occurs only at start of a lesion when right needle has impedance &gt;180 ohms</li> <li>▪ Nominal starting range is 80 to 180 ohms</li> <li>▪ Physician may continue with lesion</li> <li>▪ Message stays on for ten seconds</li> <li>▪ Alarm is <b>2 short beeps</b></li> </ul>
57	<b>Needle impedance (<math>\Omega</math>) high</b>	<ul style="list-style-type: none"> <li>▪ Occurs only at start of a lesion when both needles have impedance &gt;180 ohms</li> <li>▪ Nominal starting range is 80 to 180 ohms</li> <li>▪ Physician may continue with lesion</li> <li>▪ Message stays on for ten seconds</li> <li>▪ Alarm is <b>2 short beeps</b></li> </ul>

**Table 2-8.** Caution Messages (continued)

No.	Message	Explanation
58	<p><b>Left needle off-impedance (<math>\Omega</math>) too high</b></p> <p><b>May continue with right needle</b></p> <p><b>Needle may be in dry or hard tissue, or outside prostate</b></p>	<ul style="list-style-type: none"> <li>▪ Left needle is <b>off</b> due to high impedance (&gt;600 ohms)</li> <li>▪ Left needle position is not optimal, but treatment may be continued with right needle</li> <li>▪ Message stays on for ten seconds</li> <li>▪ Alarm is <b>3 short beeps with varied tones</b></li> </ul>
59	<p><b>Right needle off-impedance (<math>\Omega</math>) too high</b></p> <p><b>May continue with left needle</b></p> <p><b>Needle may be in dry or hard tissue, or outside prostate</b></p>	<ul style="list-style-type: none"> <li>▪ Right needle is <b>off</b> due to high impedance (&gt;600 ohms); treatment may be continued with left needle</li> <li>▪ Right needle position is not optimal, but treatment may be continued with left needle</li> <li>▪ Message stays on for ten seconds</li> <li>▪ Alarm is <b>3 short beeps with varied tones</b></li> </ul>
60	<p><b>Left needle off-temperature too low</b></p> <p><b>May continue with right needle</b></p> <p><b>Needle may be near bladder or blood vessel, or outside prostate</b></p>	<ul style="list-style-type: none"> <li>▪ Left needle is <b>off</b> due to low temperature; treatment may be continued with right needle</li> <li>▪ Left needle position is not optimal, but treatment may be continued with right needle</li> <li>▪ Message stays on for ten seconds</li> <li>▪ Alarm is <b>3 short beeps with varied tones</b></li> </ul>

Radio Frequency Generator Description | 53  
User Interface

Table 2-8. Caution Messages (continued)

No.	Message	Explanation
61	<b>Right needle off-temperature too low</b>  <b>May continue with left needle</b>  <b>Needle may be near bladder or blood vessel, or outside prostate</b>	<ul style="list-style-type: none"><li>▪ Right needle is <b>off</b> due to low temperature; treatment may be continued with left needle</li><li>▪ Right needle position is not optimal, but treatment may be continued with left needle</li><li>▪ Message stays on for ten seconds</li><li>▪ Alarm is <b>3 short beeps with varied tones</b></li></ul>
62	<b>Left needle off-temperature too high</b>  <b>May continue with right needle</b>	<ul style="list-style-type: none"><li>▪ Left needle is <b>off</b> due to high temperature; treatment may be continued with right needle</li><li>▪ Message stays on for ten seconds</li><li>▪ Alarm is <b>3 short beeps with varied tones</b></li></ul>
63	<b>Right needle off-temperature too high</b>  <b>May continue with left needle</b>	<ul style="list-style-type: none"><li>▪ Right needle is <b>off</b> due to high temperature; treatment may be continued with left needle</li><li>▪ Message stays on for ten seconds</li><li>▪ Alarm is <b>3 short beeps with varied tones</b></li></ul>

54 | **Chapter 2**  
**User Interface**

# Radio Frequency Generator Getting Started

## 3

**This chapter provides the initial instruction required to setup and start the radio frequency generator**

### **Getting Started 56**

- Introduction 56
- Patient Safety 56
- Electromagnetic Interference (EMI) 56
- Opening Radio Frequency Generator 57
- Completing Power-On Sequence 58
- Starting System 59
- Safety Shutdown Conditions 60
- Internal System Error Shutdown 62

## Getting Started

### Introduction

The following sections provide you with the basic initial steps required to setup and start the Prostiva RF Therapy Model 8930 Radio Frequency Generator.

The next chapter, Chapter 4, provides the detailed Prostiva RF Therapy instructions for use.

### Patient Safety

Appropriate patient selection is one of the first steps toward ensuring the safe and effective use of the Medtronic Prostiva RF Therapy. Additionally, treatment with the Prostiva RF Therapy requires that you read and understand all warnings, precautions, and instructions for use. For example, when preparing the patient for treatment, it is important to ensure that the return electrode is correctly positioned on the lower back and applied only once to the patient's skin. Also, during the procedure it is important to monitor and respond to the user interface information provided on the radio frequency generator display screen.

### Electromagnetic Interference (EMI)

This Model 8930 Radio Frequency Generator has been tested and found to comply with the limits for medical devices (see: "Electromagnetic Compatibility Declaration (EN60601-1-2)" on page 101). This testing shows the device provides reasonable protection against harmful interference in a typical medical installation. However, there is no guarantee that interference will not occur in a particular installation. If this equipment does cause harmful interference to other devices or is negatively impacted by other devices, the user is encouraged to try to correct the interference by one or more of the following:

- Reorient or relocate the devices.
- Increase the separation between the devices.
- Connect the equipment to an outlet on a different circuit.
- Consult the manufacturer or field service technician for help.

### Opening Radio Frequency Generator

First, place the RF Generator on a suitable table that does not obstruct the rear-panel cooling fan air flow. Position the RF Generator so that it is easy to access the on/off switch and power cord. Then, press the latch push button and position the flip-open display screen.

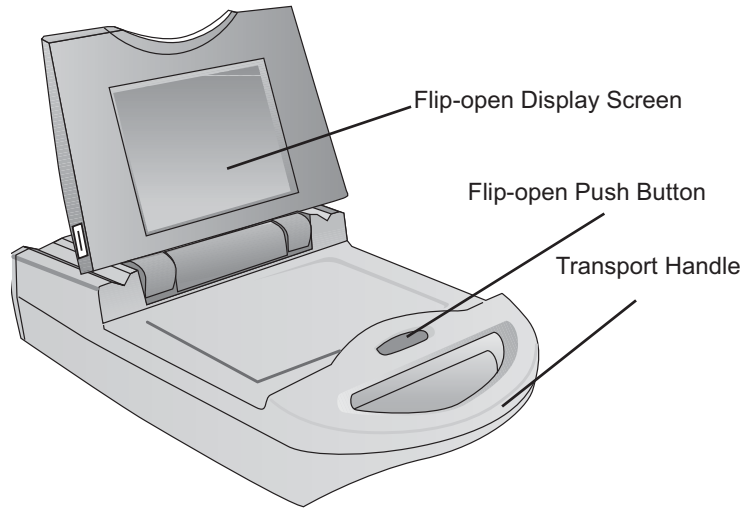
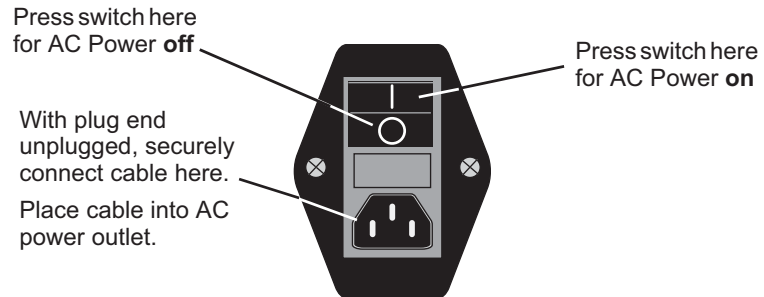

Figure 3-1. Open Display Screen.

### Completing Power-On Sequence

The power cable connector and power switch for the Model 8930 RF Generator are located on the back side of the device (Figure 3-2). The power switch toggles the AC power **on** or **off**.

1. Securely attach the Model 8930 power cable to the AC power connector.
2. Check that the power switch is in the **off** position before plugging in the power cable to an appropriate AC power outlet.
3. When the RF Generator is ready to apply power, press the power switch **on**.



**Figure 3-2.** Complete Power-On Sequence.

## Starting System

After you complete the power-on sequence, the Prostiva RF Therapy startup display appears on the screen (Figure 3-3).

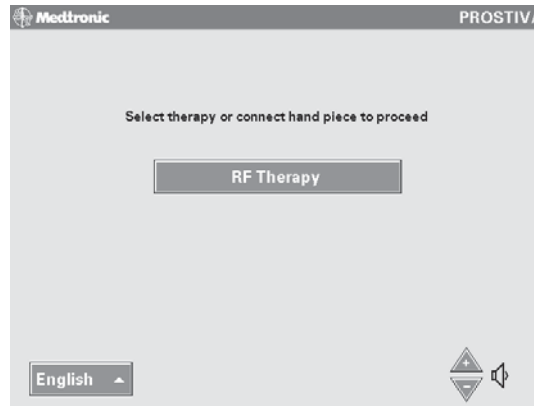

**Figure 3-3.** Monitor System Startup Display.

There are three options available on the startup display.

- Therapy
- Language (English, French, German, and Greek)
- Speaker volume (five audio levels)

If the language and speaker volume are acceptable, press the RF Therapy button to proceed to the Prostiva RF Therapy screen. If you connect the Model 8929 Hand Piece to the generator when the startup screen is displayed, the system automatically proceeds to the Prostiva RF Therapy screen.

After completing the patient assessment (“Patient Assessment” on page 64) and patient preparation (“Patient and Hand Piece Preparation” on page 68), start the patient treatment as outlined in “Patient Treatment” on page 74.

## Safety Shutdown Conditions

The radio frequency generator will perform a safety shutdown to prevent any unsafe operating condition. During a safety shutdown, RF energy delivery will be stopped and cannot be initiated again until the condition that caused the safety shutdown is corrected.

The user interface section page 33 describes the continuous realtime information that informs the clinician when there is a safety shutdown that shuts off the radio frequency energy.

The following events occur during a safety shutdown:

- Radio frequency energy is terminated
- Blue LEDs turn off
- Lesion abort alarm sounds (2 short beeps + 1 long beep)
- An “alert” message displays on the LCD screen and remains on until the cause is corrected
- Applicable digital value (eg, temperature) displays on screen
- All radio frequency energy controls are inactive until the cause is corrected

Refer to “Shutting Down System, Disconnecting Cables and Tubing System” on page 83 for instructions on how to disconnect cables and tubing system components.

**Radio Frequency Generator Getting Started** | 61  
Getting Started

**Safety Shutdown Alert Messages**

The table that follows (Table 3-1) provides a complete list of the initial line of the alert message that accompanies a safety shutdown of the radio frequency energy. For the complete message and description, please refer to Table 2-7 on page 44.

**Table 3-1.** Safety Shutdown Alert Messages

No.	First Line of Message
21	Foot switch problem
12	Generator overheated
11	Generator problem
13	Hand piece not connected
14	Hand piece problem
16	Hand piece switch problem
19	Impedance problem
31	Needle impedance ( $\Omega$ ) too high
32	Needle temperature too high
33	Needle temperature too low
17	Return electrode not connected
18	Return electrode problem
20	Temperature problem
34	Urethra temperature too high
15	Usage limit reached

62 | **Chapter 3**  
Getting Started

### Internal System Error Shutdown

If the system's internal monitoring detects a system error, it automatically halts the Prostiva RF Therapy application. When this occurs, the LCD display screen will also clear and display a solid blue image over the entire screen. If radio frequency energy is **on**, it automatically shuts **off**.

An internal system error may be caused by a temporary interference. It could also be due to a permanent hardware problem.

Complete the following steps if an internal system error shutdown occurs:

1. Stop the treatment session; if doing a lesion, retract the needles, and withdraw the hand piece.
2. Record the error code or message that displays **on** the screen; this is for the Medtronic service representative.
3. Turn **off** the AC power; wait approximately five seconds and then turn **on** the power.
4. If the solid blue image and error message persists on the screen, turn **off** the AC power and contact your Medtronic service representative.

Refer to "Shutting Down System, Disconnecting Cables and Tubing System" on page 83 for instructions on how to disconnect cables and tubing system components.

# Prostiva RF Therapy Procedure

## 4

**This chapter provides instructions for preparing the patient, setting up the radio frequency generator system, and treating the patient.**

### **Patient Assessment 64**

- Measuring Patient's Prostate 64
- Establishing Treatment Nomogram 65
- Determining Number of Treatment Planes 66
- Determining Median Lobe Treatment 67

### **Patient and Hand Piece Preparation 68**

- Attaching Return Electrode (Neutral Electrode) 68
- Preparing and Draping Patient 71
- Setting Up Hand Piece 72

### **Patient Treatment 74**

- Overview 74
- Basic Therapy Procedure Steps 74
- Initiating Lesion Procedure 77
- Shutting Down System, Disconnecting Cables and Tubing System 83

## Patient Assessment

### Measuring Patient's Prostate

Completely examine the prostate before performing the Prostiva RF Procedure. Record appropriate prostate measurements.

1. Determine the distance from the verumontanum to the bladder neck (A). This step can be performed during a standard cystoscopy or immediately before treatment.

**Note:** Reference this measurement when using Table 4-2 on page 66.

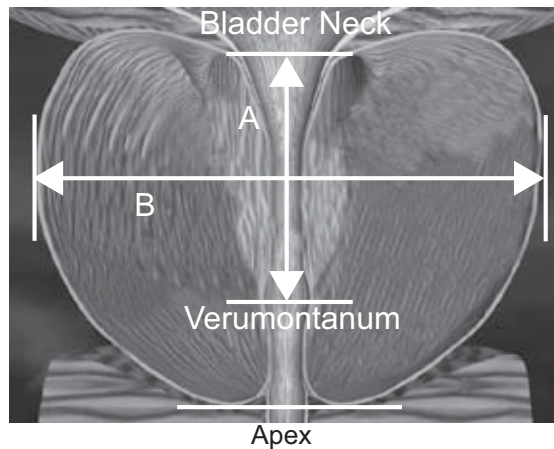

**Figure 4-1.** Prostate Measurement Example

2. Calculate the prostate volume based on ultrasonic measurement.
3. Measure the transverse width (B) of the prostate in the axial orientation at the level of the urethra from the transrectal ultrasound (TRUS).

**Note:** Reference this measurement when using Table 4-1 on page 65.

**Note:** The transverse measurement is used to determine the needle deployment settings.

### Establishing Treatment Nomogram

The Hand Piece has six preset lengths ranging from 12-22 mm with 2 mm increments. The needle shields automatically retract to protect the urethra. Table 4-1 shows the recommended guidelines based on clinical experience for needle settings. These settings are calculated by using the formula shown in Figure 4-2. Needle lengths may need to be adjusted when treating the apex and base regions versus the midpoint region.

**The selection of the appropriate needle length is in the clinician's sole medical judgement.**

**Table 4-1.** Typical Needle Settings From Step 3 Measurement

Transverse Measurement Range (mm)	Needle Length (mm)
36	12
36-40	12, 14
40-44	14, 16
44-48	16, 18
48-52	18, 20
52-56	20, 22
56-80	22

Needle length is typically calculated by taking one half of the transverse diameter of the prostate and subtracting 6 millimeters as shown in the following equation:

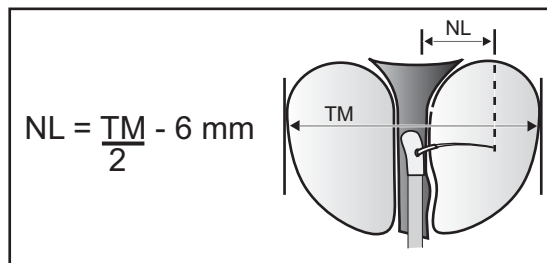

**Figure 4-2.** Needle Length Calculation Formula

**Note:** For odd-numbered transverse measurements, round down for the needle length selection.

### Determining Number of Treatment Planes

The following table (Table 4-2) provides guidelines for determining the number of treatment planes based on the distance from the bladder neck to the verumontanum. Ideally, a minimum of two planes should be treated providing that the distance from the needle placement to the bladder neck and from the needle placement to the verumontanum remains 0.75-1.0 cm.

A treatment plane consists of delivery of energy to the right and left lobes at the same level as shown in Figure 4-3.

**Note:** For each additional centimeter in length, add an additional treatment plane.

**The determination of the number of treatment planes is in the clinician's sole medical judgment.**

**Table 4-2.** Determining Number of Treatment Planes from Step 1 Measurement

Bladder Neck to Verumontanum Length	Number of Treatment Planes	Treatment Planes
<3 cm	2-3	proximal and distal
3-4 cm	3-4	proximal mid-point and distal
4-5 cm	4-5	proximal mid-point mid-point and distal

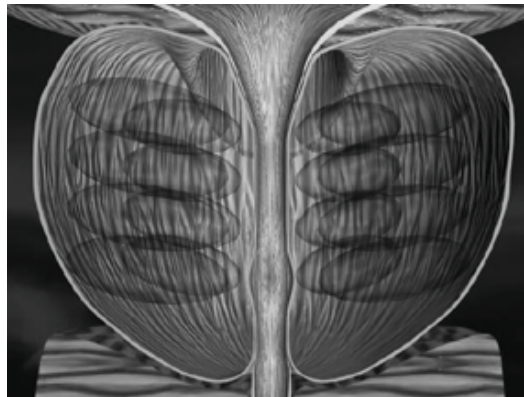

**Figure 4-3.** Example of 4 Completed Treatment Planes (8 Lesions)

### Determining Median Lobe Treatment

Treatment regions of the median lobe may be described as upper, middle, and lower. If the prostate median lobe is unusually long, then additional sites more distal to the bladder may be treated. Treatment locations (10, 12, and 2 o'clock) are recommended for the proximal (upper) end of the median lobe (Figure 4-4). The 6 o'clock location is for treatment at the distal (lower) end of the median lobe. The number of lesions typically is based on the size of the median lobe (Table 4-3).

When treating the median lobe it is necessary to visualize its size and structure. The needles of the catheter should be deployed 1 cm away from the proximal margin of the bladder neck. Advance down the median lobe under direct vision as necessary.

It is recommended that selecting a needle length of 12 or 14 mm is sufficient for treatment of the median lobe.

**The determination of median lobe treatment locations and appropriate needle lengths is the clinician's sole medical judgement.**

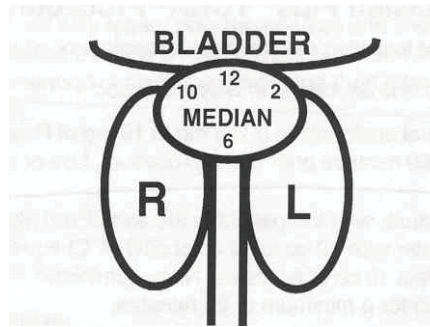

Figure 4-4. Median Lobe Treatment Locations

Table 4-3. Median Lobe Suggested Treatment

Median Lobe Dimensions (cm)	Treatment Regions	Treatment Locations
<3 cm wide	1	10, 12, 2 o'clock
3 cm wide	2 or more	10, 12, 2 o'clock
3 cm long	1	12 o'clock
>3 cm	2	6, 12 o'clock

## Patient and Hand Piece Preparation

Prepare the patient for the Prostiva RF Therapy procedure in accordance with a standard cystoscopic procedure and the following instructions. The instructions in the following sections outline the attachment of the return electrode, draping of the patient, and setting up of the hand piece. The configuration of the radio frequency generator for patient treatment is outlined in “Patient Treatment” on page 74.

### Attaching Return Electrode (Neutral Electrode)

Refer to the *Model 8929 Hand Piece Instructions for Use* for detailed instructions, warnings, and precautions regarding the use of the hand piece, return electrode, and tubing system.

**Warning:** Failure to observe the warnings outlined in the *Model 8929 Instructions for Use* or failure to use the Model 8934 Split-pad Return Electrode can result in low system output, failure of the system to function properly, or patient injury (eg, burns).

1. Open the package and remove the Model 8934 Split-pad Return Electrode.
2. Slowly remove plastic backing to expose conductive/adhesive area without creasing the return electrode surface (Figure 4-5). Discard the plastic backing.

**Note:** If the electrode is creased during removal, discard and use a new return electrode.

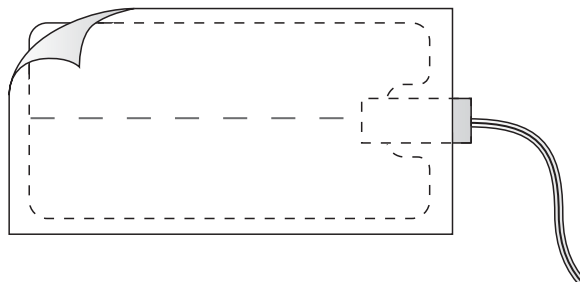
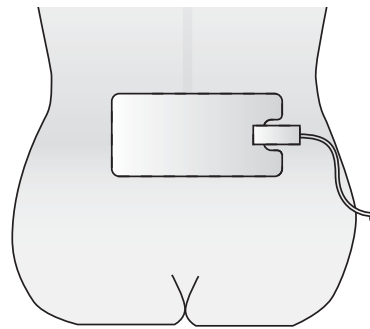

**Figure 4-5.** Carefully Remove Return Electrode Backing.

**Prostiva RF Therapy Procedure** | 69  
Patient and Hand Piece Preparation

3. Place the return electrode onto the patient.
  - a. Have the return electrode cable side face toward the radio frequency generator. Then, place the return electrode horizontally across the lower portion of the small of the back directly above the buttocks as shown in Figure 4-6.
  - b. Apply the return electrode at one edge (Figure 4-7) and press firmly; smooth to opposite edge so the entire area is completely attached to the patient's skin.

**⚠ Warning:** Do not place over metal prostheses or monitoring electrodes. Avoid placement of the return electrode over scars, bony prominences, or excessive hair. Return electrodes placed in these areas can affect circuit impedance. This can result in low system output, failure of the system to function properly, or patient injury (eg, burns).



**Figure 4-6.** Position Return Electrode at Lower Back.

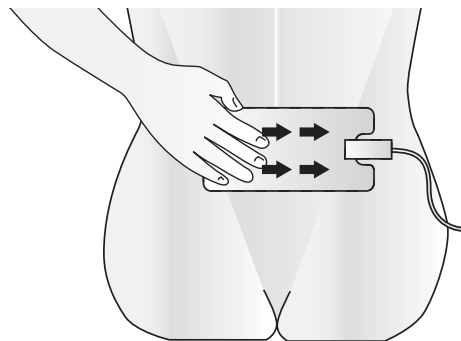

**Figure 4-7.** Securely Apply Return Electrode to Lower Back.

## Chapter 4 Patient and Hand Piece Preparation

4. Inspect the return electrode to ensure complete skin contact and that no creases or air bubbles are present. If complete skin contact is not achieved, or if the return electrode is creased, remove and replace with a new Model 8934 Return Electrode.

 **Warning:** Do not use an improperly applied or connected return electrode. Faulty application of the return electrode, or partial connections, may result in low system output or failure of the equipment to function properly or patient injury (eg, burns).

 **Caution:** Place monitoring electrodes as far from the return electrode as possible. Needle monitoring electrodes are not recommended. In any case, the use of monitoring systems incorporating high frequency (HF) current limiting devices are recommended. Erroneous readings can occur if monitoring electrodes are placed too close to the return electrode.

5. Connect the return electrode when the patient and the system are ready to begin treatment. Connect the return electrode cable by fully inserting the connector into the connector port on the RF generator therapy panel.

**Prostiva RF Therapy Procedure** | 71  
Patient and Hand Piece Preparation

### Preparing and Draping Patient

1. Prepare and drape the patient following standard cystoscopic procedure.
2. Inspect the return electrode to ensure complete skin contact and that no creases or air bubbles are present.

**Note:** If complete skin contact is not achieved or if return electrode is creased, remove and replace with a new return electrode.

3. Forty-five to sixty minutes before the procedure begins, it is recommended that you administer an oral analgesic and an oral sedative/hypnotic.
4. Twenty minutes prior to the procedure:
  - a. Place the patient in the semi-Fowler's position.
  - b. Empty the patient's bladder with a catheter.
  - c. Fill the patient's urethra through the catheter with an appropriate liquid analgesic.
  - d. Then, slowly pull the catheter out while continuing to instill the remaining analgesic.
  - e. Next, administer an appropriate gel analgesic uretherally, and clamp the penis for a minimum of 20 minutes.

**The above procedures are recommendations based on clinical experience. Selection and administration of appropriate anesthetic or analgesic agents are in the clinician's sole medical judgement.**

72 | **Chapter 4**  
Patient and Hand Piece Preparation

**Setting Up Hand Piece**

Complete the instructions outlined below to configure the Model 8929 Hand Piece as shown in the (Figure 4-8) illustration.

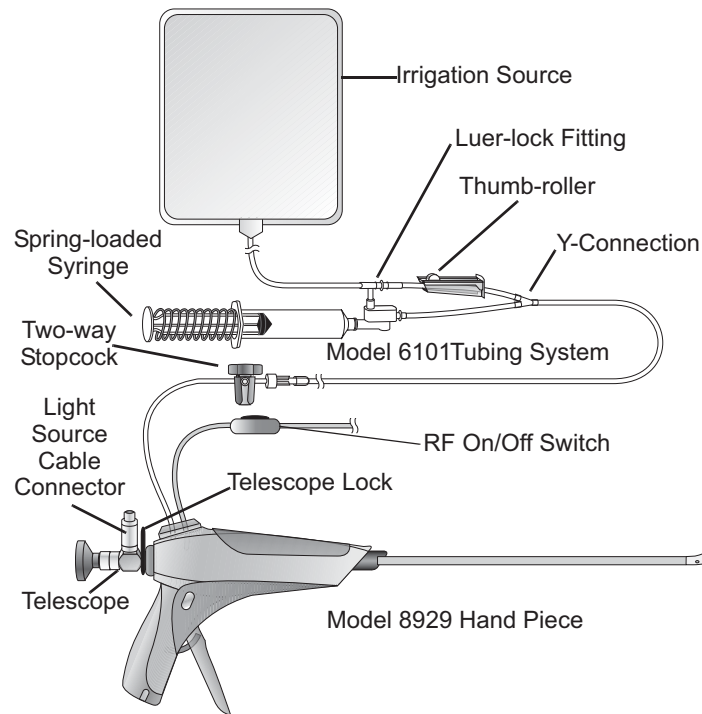

**Figure 4-8.** Set Up Hand Piece and Attached Accessories.

1. Use sterile technique to open the Model 8929 Hand Piece sterile tray and place the hand piece into the sterile field.
- △ **Caution:** The hand piece useful life and sterility may be compromised if the device is removed from the sterile packaging or connected to the RF generator more than 30 minutes prior to starting the procedure.
2. Open and connect the sterile Model 6101 Tubing System.
  - a. Check that the thumb-roller clamp is closed.
  - b. Attach the irrigation source tubing to the tubing system at the Luer-lock fitting that is connected to the thumb-roller clamp.
  - c. Attach the tubing from the Y-connection to the hand piece two-way stopcock.

**Prostiva RF Therapy Procedure** | 73  
Patient and Hand Piece Preparation

3. Connect the sterile telescope.
  - a. With the telescope lock down, insert the sterile telescope into the hand piece with its light cord connector in the 12 o'clock position.
  - b. Carefully advance the telescope fully into the hand piece.
  - c. Slide the telescope lock up to secure the telescope in place.
- △ **Caution:** Do not advance the telescope into the hand piece telescope port without first ensuring that the lock is in the unlocked (down) position. Advancing the telescope into the hand piece with the lock in the locked (up) position can result in damage to the hand piece or telescope.
4. Use sterile technique to connect the light source cable (non-sterile) to the telescope.
5. Use the needle length selector knob to select the appropriate needle length, as you determined earlier.
6. Deploy needles and visually inspect the needles and shields.
7. Then, fully retract the needles and shields.

74 | **Chapter 4**  
Patient Treatment

## Patient Treatment

### Overview

This section lists the basic procedure steps of the Prostiva RF Therapy procedure and the detailed instructions for the radio frequency treatment. The basic procedure steps are based on the system diagram shown on the inside base of the Model 8930 Radio Frequency Generator. It includes the procedure steps from the preparation instructions outlined in the previous sections, as well as those outlined in this section.

### Basic Therapy Procedure Steps

The following table outlines the basic procedure steps shown on the radio frequency generator system diagram on the inside top of the case (Table 4-4 on page 75).

- ⚠ **Warning:** Do not route the hand piece radio frequency cable so that it contacts the patient. Accidental damage to a cable in contact with the patient can result in low system output, failure of the system to function properly, or patient injury (eg, burns).
- ⚠ **Warning:** Do not use the hand piece, or temporarily store it on a table, until you have confirmed that the trigger mechanism is fully forward. Failure to place the trigger mechanism into the needles-fully-retracted position can leave the needles and shields partially deployed. This can result in possible personal injury if the needles come in contact with the patient or others.

**Prostiva RF Therapy Procedure**  
Patient Treatment

75

**Table 4-4.** Prostiva RF Therapy Procedure: Basic Steps

To	Do This
1. Connect the AC power cord to the radio frequency generator.	Check that the power switch is <b>off</b> . Next, attach the radio frequency generator's AC power cord to the back panel power input connector. Then, plug the power cord into an appropriate AC outlet.
2. Turn the radio frequency generator power <b>on</b> .	Set the power switch to the <b>on</b> position. Check that the display lights up and shows the startup screen.
3. Attach the return electrode to the patient.	Open and remove the backing from the return electrode. Next, securely attach the return electrode to the patient's lower back.
4. Connect the return electrode cable to the radio frequency generator therapy panel.	Pass the return electrode out of the patient treatment field for connection to the radio frequency generator.
5. Connect the tubing system between the hand piece and an irrigation source.	Use a sterile technique to open the hand piece and tubing system packages. Attach the tubing system to the hand piece stopcock and the irrigation source. Optionally, connect to an aspirating syringe.
6. Attach the telescope to the hand piece.	With the telescope lock down, insert the sterile telescope into the hand piece. Slide the telescope lock up to secure the telescope in place. Connect the light source cable to the telescope.
7. Set the hand piece needle-length selector dial to the appropriate value.	Based on your patient's prostate size and transverse measurement and your medical judgement, use the needle length formula (Figure 4-2) to determine the appropriate needle length selection.

76 | Chapter 4  
 Patient Treatment

**Table 4-4.** Prostiva RF Therapy Procedure: Basic Steps

To	Do This
8. Connect the hand piece to the radio frequency generator.	Pass the cable out of the sterile field for connection to the radio frequency generator. Connecting the hand piece automatically starts the Prostiva RF Therapy application software and displays the Prostiva RF Therapy screen.
Note	If the optional Model 60883 Foot Switch will be used, also connect it.

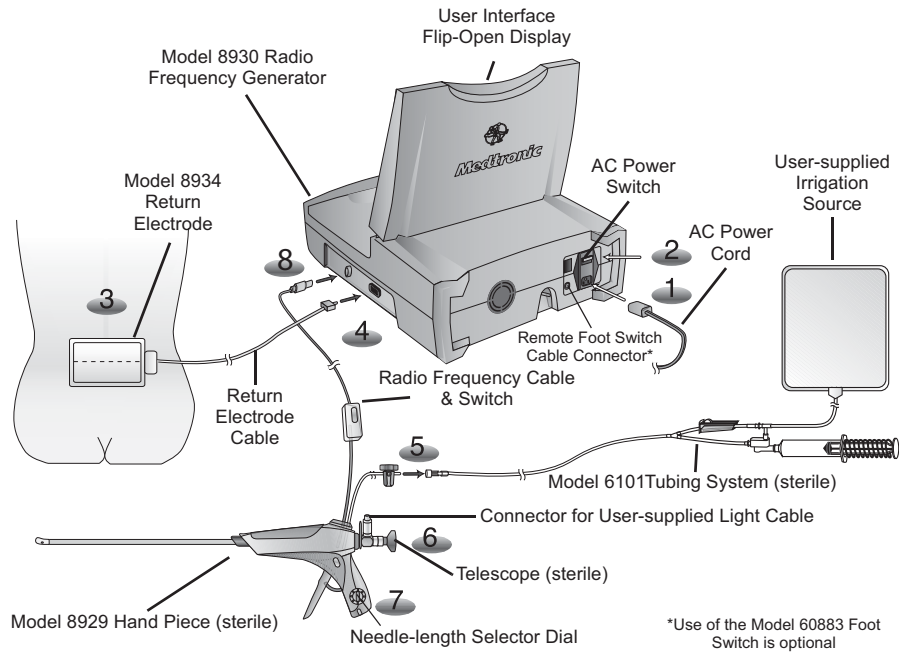

**Figure 4-9.** Complete System Cable and Irrigation Tubing Connections.

### Initiating Lesion Procedure

1. Confirm that the radio frequency generator system components are ready for the lesion procedure.
2. Confirm that the Prostiva RF Therapy screen is displayed (Figure 4-10); press the RF Therapy button.

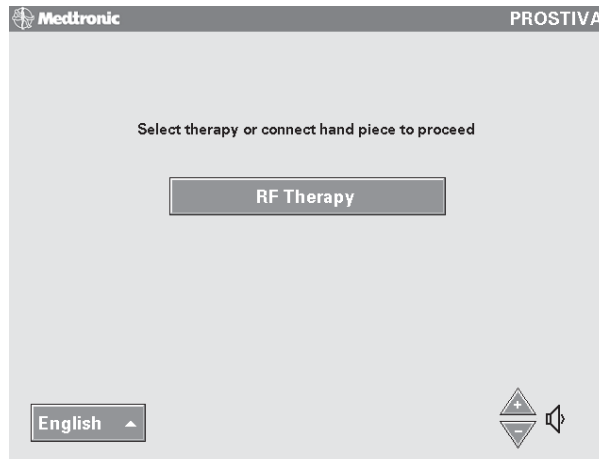

Figure 4-10. Confirm Prostiva RF Therapy Screen Display.

3. Confirm that the “System Ready” message appears on the screen display (Figure 4-11).

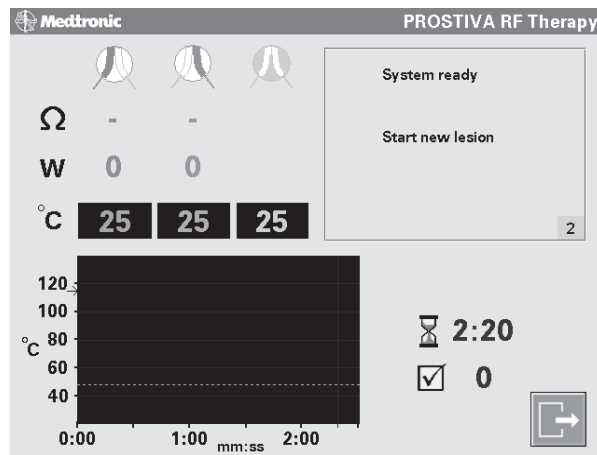

Figure 4-11. Confirm “System Ready” Status on Screen Display.

78 | **Chapter 4**  
Patient Treatment

4. Coat the tip of the hand piece with a generous amount of water-soluble lubricating or anesthetizing gel. Carefully insert the hand piece into the urethra through the meatus.
5. Use the hand piece telescope to locate the bladder neck and the verumontanum.
6. Adjust the telescope as necessary for the best view of the patient's anatomy.
7. Use the predetermined measurements to position the hand piece tip 0.75-1.0 cm distal from the bladder neck (refer to "Establishing Treatment Nomogram" on page 65).
8. Position the needles at the deployment site by rotating the hand piece sheath completely to the appropriate lobe.

**Note:** The needles exit the hand piece at approximately a 90 degree angle.

9. Reposition the telescope to view and locate the site for needle deployment.

**Warning:** Do not deploy the needles, until the hand piece is properly placed. Proper placement of the needles and accurate needle length selections are essential. Improper positioning of the hand piece, misplacement of the needles, or improper needle length selections could result in damage to the external sphincter or urethra, perforation of the prostatic capsule or bladder neck, incomplete ablation, incontinence, or damage to the rectum.

**Notes:**

- The first needle deployment should be approximately 0.75-1.0 cm from the bladder neck.
  - Needle deployments in the apex region should be at least 0.75-1.0 cm above the verumontanum.
  - When treating the median lobe, it is recommended that you select a needle length of 12 mm or 14 mm.
  - It is necessary to visualize the size and structure. It is recommended that you deploy the needles 1.0 cm away from the proximal margin of the bladder neck. Then, as needed, advance down the median lobe under direct vision.
10. To fully deploy the needles and appropriately retract the shields, firmly pull the trigger mechanism all the way back until the trigger reaches the automatic stop.

**Note:** Confirm that the hand piece tip is flush against the urethra.

**Prostiva RF Therapy Procedure** | 79  
Patient Treatment

11. Start the radio frequency power delivery by pressing and releasing the on/off switch on the hand piece cable. If using the optional foot switch, press and release the on/off foot switch.

**Note:** The radio frequency energy on/off switches function as press-and-release switches. They are not designed to be held in the pressed-down position.

**Note:** The lesion time is automatically set for 2:20 minutes. When the lesion starts, the time decrements by seconds until lesion time expires. Then, the radio frequency energy automatically terminates.

12. Confirm that the “Lesion In Progress” message appears on the screen display (Figure 4-12), and monitor the various outputs (eg, temperature, lesion time) during the procedure.

**Warning:** Carefully monitor the urethral temperature during the lesion. Immediately irrigate the urethra if it reaches 43° C, which automatically triggers a caution tone and message; if the temperature reaches 47° C, the radio frequency energy automatically shuts off. Failure to cool the urethra can result in possible injury to the patient’s urethra.

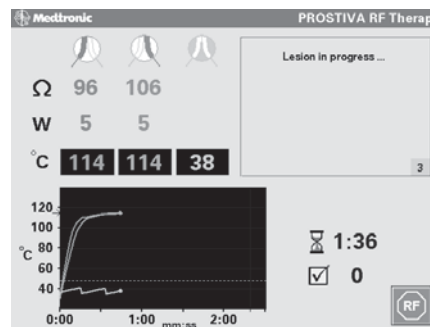

**Figure 4-12.** Confirm “Lesion In Progress” and Monitor Outputs on Screen Display

**Warning:** Do not continue treatment if a return electrode error condition is detected. Ensure that the return electrode is properly placed on the patient by monitoring user-interface feedback. Feedback is provided by screen display data, error messages, and audible alarms. Take the appropriate action from user interface message to correct any return electrode problems. Otherwise, remove and replace return electrode with new one. Continuing treatment with a faulty return electrode connection can result in possible patient injury.

80 | **Chapter 4**  
Patient Treatment

**△ Caution:** Continuous irrigation is not required for the Prostiva RF procedure. Continuous irrigation can cool down the needle temperatures, which may reduce the optimal lesion effect.

**Note:** To keep the urethra cooled, irrigate with small flushes of irrigation fluid (approximately 0.5-1.0 ml). It is recommended that continuous flushing only be used during positioning and visualization then turned off.

**Note:** To drain bladder, open stopcock connected to the aspiration position.

13. When the lesion treatment is complete, confirm that the “Lesion Complete” message appears on the screen display (Figure 4-14), and fully retract the hand piece trigger mechanism (Figure 4-13).
  - a. Move the trigger mechanism fully forward until it moves into the fully retracted position; this fully retracts the needles and the shields.
  - b. Confirm that the trigger mechanism is fully up and that the needle retraction window shows solid white and no blue.
  - c. Remove or reposition the hand piece as you deem appropriate.

**⚠ Warning:** Do not continue, reposition, or remove the hand piece until you have confirmed that the trigger mechanism is fully forward. Failure to place the trigger mechanism into the needles-fully-retracted position can leave the needles and shields partially deployed. This can result in possible patient injury if the hand piece is repositioned or removed from the urethra.

**Note:** If the telescope becomes damaged or otherwise non-functional during a treatment, it is recommended that the lesion be completed and the needles fully retracted prior to removing the entire hand piece from the patient. If there is a loss of illumination due to a light source or camera malfunction, the hand piece does not require removal. A spare telescope and fiber-optic light source/cable are recommended.

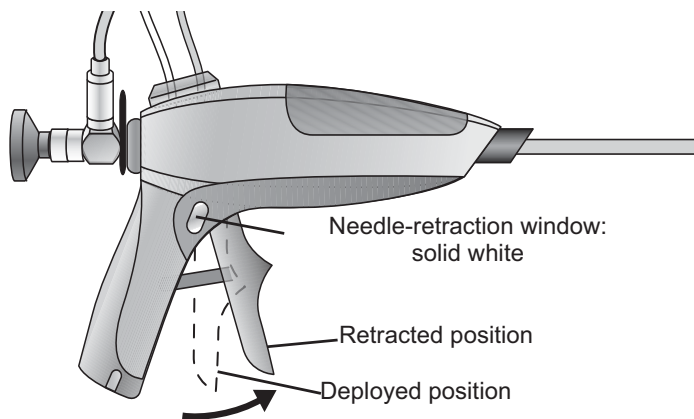

Figure 4-13. Fully Retract the Trigger Mechanism.

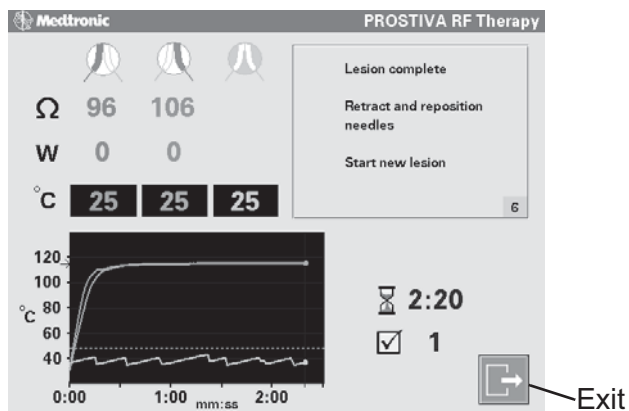

Figure 4-14. Confirm “Lesion Complete” on Therapy Screen Display.

14. Position the hand piece for the next needle deployment.

**Note:** After treating one lesion, fully retract the needles and then rotate the hand piece to the contralateral side. Then move distally down the urethra approximately 1 cm.

15. Repeat steps 8 through 14 for a new lesion, until the entire prostate is treated, or complete such treatment as deemed appropriate.
16. Press the “Exit” icon button (Figure 4-14) to access the “New Patient” window on the screen display (Figure 4-15).

82 | **Chapter 4**  
Patient Treatment



**Figure 4-15.** Confirm the “Patient” on Screen Display

17. Press the “New Patient” button to access the “System Ready” screen display; press “Resume” to return to the previous screen; or press “Quit” to quit the therapy and transfer to the start-up screen.
18. Repeat the therapy steps until you treat the entire prostate, or complete such treatment as you deem appropriate.

## Shutting Down System, Disconnecting Cables and Tubing System

When the patient's treatment is completed, or there is a safety shutdown, and no further use of the system is required, complete the following steps to disconnect the cables and tubing system:

1. If not previously done, carefully remove the Model 8929 Hand Piece from the patient.

**⚠ Warning:** Do not continue, reposition, or remove the hand piece until you have confirmed that the trigger mechanism is fully forward. Failure to place the trigger mechanism into the needles-fully-retracted position can leave the needles and shields partially deployed. This can result in possible patient injury if the hand piece is repositioned or removed from the urethra.

2. Turn off the Model 8930 Radio Frequency Generator system power.
3. Remove the Model 8943 Return Electrode Cable from the radio frequency generator by pulling straight out on its connector plug. Carefully remove the return electrode from the patient by gently peeling it back from the patient.
4. Remove the Model 8929 Hand Piece radio frequency cable from the generator by pulling straight out on its connector plug.
5. If installed and no additional treatments are scheduled for this use, remove the Model 60883 Remote Foot Switch cable by grasping release mechanism on the connector and pulling straight outward to disengage and remove.
6. If no additional treatments are scheduled for this use, remove the power cord from the wall socket outlet; then remove the power cable from the back of the generator and store it with the generator.
7. Disconnect the user-supplied light cable from the telescope, and remove the telescope from the Model 8929 Hand Piece.

**Note:** The telescope can be cleaned and resterilized in accordance with the instructions in the telescope instructions for use. The Model 8929 is a single-use only device and it cannot be reuse.

8. Close the Model 6101 Tubing System thumb-roller clamp and disconnect the tubing system from the hand piece.
9. Discard the Model 8929 Hand Piece, Model 8934 Return Electrode, and Model 6101 Tubing System in accordance with local environmental regulations.

84 | **Chapter 4**  
Patient Treatment

# TUNA Therapy Clinical Overview

# 5

**This chapter provides an overview of the TUNA Therapy clinical information.**

## **Overview 86**

Indications	86
Contraindications	86
Warnings	87
Precautions	89
Clinical Studies	91
Study Design	91
Adverse Events	92
Efficacy Data	93

## Overview

The Medtronic TUNA (Transurethral Needle Ablation) Therapy is a minimally invasive treatment for patients with lower urinary tract symptoms due to benign prostatic hyperplasia (BPH). The Medtronic Prostiva RF System uses precisely focused radio frequency energy to ablate prostate tissue, which helps to reduce the constriction of the urethra and relieve BPH voiding symptoms.

The Medtronic Prostiva RF Therapy is clinically equivalent to the Medtronic TUNA (Transurethral Needle Ablation) Therapy. The Medtronic Prostiva RF Therapy and System represent a new version of the radio frequency generator and hand piece that are used for the same transurethral needle ablation procedure for treating benign prostatic hyperplasia.

## Indications

The Prostiva RF System is indicated for the treatment of symptoms due to urinary outflow obstruction secondary to benign prostatic hyperplasia (BPH) in men over the age of 50 with prostate sizes between 20 and 50 cm<sup>3</sup>.

## Contraindications

Patients with the following conditions should not be treated:

- Patients with an active urinary tract infection
- Neurogenic, decompensated or atonic bladder (patients with suspect bladder function should undergo a urodynamic evaluation to rule out atonic, decompensated, or neurogenic bladder syndrome)
- Urethral strictures or muscle spasms that prevent insertion of the hand piece sheath
- Bleeding disorders or patients taking anticoagulation medication unless antiplatelet medication has been discontinued for at least 10 days
- ASA class group V patients
- Clinical or histological evidence of prostatic cancer or bladder cancer
- A prostate gland which is less than 34 mm or greater than 80 mm in transverse diameter

**TUNA Therapy Clinical Overview** | 87  
Overview

- Presence of any prosthetic device in the region that may interfere with the procedure
- Patients whose prostate has been previously treated with non-pharmacological therapies (such as TUMT, Laser, or TURP)
- Presence of a cardiac pacemaker, implantable defibrillator, or malleable penile implants
- Patients with any component(s) of an implantable neurostimulation system; energy from the Prostiva RF System may be transferred through the implanted system and may damage the patient's tissue in the area of the implanted system components. This applies whether the neurostimulation system is "off" or "on". The neurostimulation system components may also be damaged.

## Warnings

Read all Warnings, Precautions, and Instructions for Use carefully prior to use. **Failure to read and follow all instructions, or failure to observe all stated warnings, could cause serious injury or death to the patient.**

- **Return electrode-** Failure to properly place the return electrode may result in patient burns or poor electrical performance. Refer to "Attaching Return Electrode (Neutral Electrode)" on page 68, for complete instructions.
- **Return electrode-** The Model 8934 Return Electrode is designed for use only with the Medtronic Model 8930 RF Generator.
- **Patient grounding-** The patient should not come into contact with metal parts that are earthed or that have an appreciable capacitance to earth.
- **Skin-to-skin contact-** Antistatic sheeting is recommended for protection. Skin-to-skin contact (between the legs or between the arms and body) should be avoided, for example, by insertion of dry gauze.
- **Needle placement-** Proper placement of the needles and accurate needle length selections are essential. Improper positioning of the hand piece, misplacement of the needles, or improper needle length selections could result in damage to the external sphincter or urethra, perforation of the prostatic capsule or bladder neck, incomplete ablation, incontinence, or damage to the rectum.

88 | Chapter 5  
Overview

- **Sterile instrument-** If a sterile instrument is accidentally dropped while connected to the RF generator, it must not be used. If this occurs, take the following steps immediately to avoid risks of using a contaminated hand piece and the possibility of electrical shock:
  - a. Turn **off** the RF generator.
  - b. Disconnect the RF generator power cord from the power outlet.
  - c. Disconnect the RF cable from the RF generator.
  - d. Dispose of the hand piece properly according to established facility policy and procedure; be sure to remove telescope.
- **Single-use-only devices-** The hand piece, return electrode, and tubing system are intended for single use only. Do not reuse, reprocess, or resterilize these devices. Reuse, reprocessing, or resterilization may compromise the structural integrity of the devices and/or create a risk of contamination of the devices, which could result in patient injury, illness, or death. Discard according to local environmental regulations.
- **Safety and efficacy-** The safety and efficacy of the treatment in patients with the following conditions has not been established:
  - Patients with a median lobe that grows into the bladder and collapses across the bladder
  - Patients with a transverse diameter of the prostate gland that is greater than 64 mm
  - Patients with prostate size above 50 cm<sup>3</sup>
  - Patients in ASA American Society of Anesthesiologists (ASA) Risk Category Class IV
- **Heart disease-** Patients with cardiac arrhythmia, hypertension uncontrolled by medication, cardiac disease, or congestive heart failure should be cleared by their cardiologist before having a Prostiva RF Procedure.
- **Packaging inspection-** Inspect each package prior to use. Do not use if package is opened or damaged.
- **Aseptic technique-** Use aseptic technique in all procedures. In areas where fluid spillage is likely to occur, use plastic sheeting to protect the generator.

**TUNA Therapy Clinical Overview** | 89  
Overview

- **Flammable agents-** Flammable agents used for cleaning or disinfecting are not recommended. If used, they should be allowed to evaporate before application of radio frequency energy. Because there is a risk of pooling flammable solutions under the patient, any pooled fluid should be removed before using the radio frequency generator.
- **Equipment failure-** The failure of the radio frequency generator could result in an unintended increase of output power.
- **Explosive gases-** There is danger of ignition of endogenous gas near the high frequency generator and accessories (including the hand piece and telescope). Anesthetic mixtures with air, oxygen, or nitrous oxide should be restricted from the procedure site. When some materials such as cotton, wool, and gauze are saturated with oxygen, there is a danger of ignition from radio frequency energy.
- **Electric shock-** To avoid the risk of electric shock, this equipment must only be connected to a supply mains with protective earth (eg, a properly-grounded electrical outlet). Electric shock can lead to equipment damage, serious patient injury, or death.

USA Grounding reliability can only be achieved when the equipment is connected to an equivalent receptacle marked "Hospital Only" or "Hospital Grade".

## Precautions

The safety and effectiveness of treating patients with the following conditions has not been established:

- Patients with an interest in the preservation of future fertility
- Patients with previous rectal surgery other than hemorrhoidectomy, previous radical pelvic surgery or pelvic irradiation
- Patients with PSA > 10 ng/ml. Patients with PSA values between 4-10 ng/ml must have negative core biopsies
- Patients taking any medications that may affect the prostate and bladder, such as 5-alpha reductase inhibitors, antiandrogens, and gonadotropin-releasing hormonal medications within two months of the Prostiva RF Therapy Procedure

90 | **Chapter 5**  
Overview

- Patients taking any medications that may affect the prostate and bladder (alpha and beta blockers, antihistamines, antidepressants, anticonvulsants, antispasmodics, and anticholinergics) within one week of the Prostiva RF Therapy Procedure

The treating clinician should be present at all times and the following additional cautions should be observed with respect to the patient's safety:

- The system should only be used by clinicians trained in prostate surgery.
- The Prostiva RF Therapy Procedure, unlike transurethral resection of the prostate, does not provide tissue samples for pathological examination. For this reason, it is recommended that patients treated with the system be followed on an annual basis to assess any prostatic changes.
- Interference produced by the operation of the high frequency surgical equipment may adversely influence the operation of other electronic equipment.
- Inspect the outside packaging of the hand piece and tubing system for integrity to ensure sterility.
- Inspect all components prior to use for any obvious signs of damage that may have occurred during transit and/or storage. In particular the return electrode should be checked prior to use.
- The Model 8929 Hand Piece is designed to operate only in conjunction with the Model 8930 Radio Frequency Generator. It is not designed to operate with any other radio frequency generator or electrosurgical power source.
- Excessive risk (leakage) current may result if this equipment is connected to anything other than the manufacturer's recommended power distribution system.
- Use only Medtronic-recommended sterilization techniques outlined in the appropriate telescope *Instructions for Use* to process the telescope.
- When attached to a high energy light source, the telescope may emit a high intensity light beam that can be hazardous if viewed directly. Keep tip of telescope or hand piece pointed away from patient's eyes and avoid looking directly into light beam.
- Do not modify this equipment. Modification of this equipment can result in damage to the device, causing the device to malfunction or become unusable.

**TUNA Therapy Clinical Overview** | 91  
Overview

Additional warnings and precautions applicable to specific procedures can be found at appropriate places in this system user guide.

## Clinical Studies

Clinical studies using the TUNA Procedure were performed at multiple medical institutions throughout the United States. Patients with lower urinary tract symptoms secondary to benign prostatic hyperplasia (BPH) were enrolled in separate clinical studies to determine the safety and efficacy of the TUNA Therapy.

## Study Design

One clinical study included a multicenter, single blind, randomized study comparing the TUNA Therapy to TURP (Transurethral Resection of the Prostate). Of the 167 patients treated in the study, 111 were treated with the TUNA Therapy and 56 were treated with TURP. Safety was measured by the rate and severity of adverse events. Efficacy was evaluated by measuring peak-flow rate and AUA (American Urological Association) symptom score.

Patients 45 years or older with lower urinary tract symptoms secondary to the diagnosis of BPH who have both lateral and median lobe involvement were enrolled in additional two studies (PM1 and P01) to determine safety and efficacy.

The prostate glands were between 30 to 100 grams. Of the 50 patients treated in the studies, 45 were followed up for six months and 24 had up to one-year follow-up data.

### Adverse Events

The clinical trials demonstrated that the TUNA Procedure can be performed without the need for general or regional (spinal) anesthesia; however, sedation is often used. Treatment with the TUNA Procedure is associated with few side effects and adverse events. The following table (Table 5-1) summarizes the safety data of patients from the original TUNA Therapy versus TURP study (lateral lobe only) and that from the two additional studies (P01 and PM1) that included treatment of patients having a degree of median lobe hyperplasia.

**Table 5-1.** Adverse Events

Adverse Event	Original Tuna Therapy Lateral Lobe Study	P01 Lateral and Median Lobe Study	PM1 Lateral and Median Lobe Study
Obstruction	44%	0%	0%
Catheterization (for urinary retention)	41%	15%	6%
Bleeding	29%	9%	6%
Pain/Discomfort	23%	(included in Dysuria) <sup>a</sup>	(included in Dysuria) <sup>a</sup>
Urgency	8%	(included in Dysuria) <sup>a</sup>	(included in Dysuria) <sup>a</sup>
Frequency	8%	(included in Dysuria) <sup>a</sup>	(included in Dysuria) <sup>a</sup>
Urinary Tract Infection	6%	12%	0%
Dysuria	2%	15% <sup>a</sup> (irritative symptoms)	6% <sup>a</sup> (irritative symptoms)
Scarring/Stricture	<2%	0%	0%
Impotence	<2%	0%	0%
Retrograde Ejaculation	<1%	3% (partial)	0%
Incontinence	0%	0%	0%

<sup>a</sup> In the lateral and median lobe studies, dysuria was described as irritative voiding symptoms, which include pain, discomfort, or frequency.

### Efficacy Data

The original prospective clinical trial (lateral lobe only) was performed at eight (8) medical centers across the United States. One hundred sixty-seven (167) men 50 years of age or older with symptomatic BPH were enrolled in this original trial. One hundred twenty-one (121) of these patients were randomized to either the TUNA Therapy or TURP: sixty-five (65) were treated with the TUNA Therapy and fifty-six (56) underwent TURP. Forty-six (46) additional non-randomized patients were treated with TUNA, making the total TUNA-treated population one hundred eleven (111).

Mean values for AUA (American Urological Association) Symptom Score, Peak Flow Rate, Post Void Residual Volume, and Quality of Life (QOL) score between the TUNA Therapy and TURP groups were measured at baseline, 6 months, and 12 months following the treatment, respectively (Table 5-2).

**Table 5-2.** Efficacy Data of the TUNA Therapy vs. TURP Study

Parameter	Baseline	6 Months	12 Months
AUA Symptom			
TUNA Therapy	23.8	10.6	11.9
TURP	24.1	7.9	7.8
Peak Flow Rate			
TUNA Therapy	8.9	13.4	14.8
TURP	8.9	21.0	21.1
Post-Void Residual Value			
TUNA Therapy	91.4	63.6	65.9
TURP	81.9	45.6	47.1
Quality of Life			
TUNA Therapy	4.7	1.9	1.9
TURP	4.8	1.6	1.4

94 | **Chapter 5**  
 Overview

Similar results were seen from the additional studies (lateral and median lobes). Tables 5-3 and 5-4 demonstrated the efficacy results of all the studies.

**Table 5-3.** Total Symptom Score Overview

Visit	Original TUNA Therapy Lateral Lobe Studies (American Urological Association Symptom Score)	P01 Lateral and Median Lobe Studies (International Prostate Symptom Score)	PM1 Lateral and Median Lobe Studies (International Prostate Symptom Score)
Pretreatment	24.6	21.0	24.0
1 Month	12.5	16.0	13.0
3 Months	9.6	10.0	10.0
6 Months	10.1	10.0	5.0
12 Months	10.6	11.0	N/A

**Table 5-4.** Peak Uroflow Rate (Qmax) Overview

Visit	Original TUNA Therapy Lateral Lobe Studies (American Urological Association Symptom Score)	P01 Lateral and Median Lobe Studies (International Prostate Symptom Score)	PM1 Lateral and Median Lobe Studies (International Prostate Symptom Score)
Pretreatment	8.306	8.6	6.4
1 Month	16.565	10.2	11.4
3 Months	15.024	12.0	15.1
6 Months	14.748	13.7	11.0
12 Months	13.432	12.7	N/A

## Specifications

# 6

**This chapter provides a list of general device specifications for reference. The information provided is nominal and approximate.**

### **Device Specifications 96**

Radio Frequency Generator 96

Hand Piece 99

Telescope 99

Return Electrode 100

Remote Foot Switch (optional) 100

Electromagnetic Compatibility Declaration (EN60601-1-2) 101

## Device Specifications

### Radio Frequency Generator

**Table 6-1.** Model 8930 Radio Frequency Generator Specifications<sup>a</sup>

Description	Specification
Classification	IEC60601-1, Class I, Type BF, IPX0, no sterilization, continuous use  This device complies with Part 18 of the FCC rules.  This ISM device complies with Canadian ICES-001.
Operating modes	Automatic dual needle Automatic single needle
RF output power	2 channels x 15 W (+/-10%) into 35–600 Ohms for Prostiva RF Therapy software calibration—generator is rated at 2 channels x 50 W (+/-10%) into 20–600 Ohms
Impedance range	35-600 Ohms, nominal
Impedance measurement accuracy	+/- 10% + 5 Ohms for 50–200 Ohms +/- 20% + 5 Ohms for 0–50 & 200–999 Ohms
System control	System only allows radio frequency energy power output when the measured load impedance is within 35 to 600 Ohms for one or both channels
Temperature-sensor range	15° C to 140° C (59° F to 284° F)
Temperature accuracy	+/-2° C for 15° C to 60° C (+/-4° F for 59° F to 140° F) +/-3° C for 60° C to 140° C (+/-5° F for 140° F to 284° F)
Urethral temperature limits	>43° C (109° F) caution tone sounds and message displays >47° C (117° F) radio frequency power turns off, alert tone sounds, alert message displays

**Table 6-1.** Model 8930 Radio Frequency Generator Specifications<sup>a</sup> (continued)

Description	Specification
RF output power frequency	473 kHz +/- 2 kHz sinusoidal, unmodulated
Input power	100-240 VAC, 200 VA, 50/60 Hz
Maximum RF voltage (per channel)	173 Vrms (at 50 W, 600 Ohms-hardware limit) 95 Vrms (at 15 W, 600 Ohms-software limit)
Maximum RF current (per channel)	1.56 A (hardware limit) 0.66 A (software limit)
Fuse protection	Two, T3.15A (5 mm x 200 mm), 250 V, slow-blow fuses
Case dimensions	36 cm W x 56 cm L x 15 cm H (closed) & 38 cm H (open) 14 in W x 22 in L x 6 in H (closed)/15 in H (open)
Weight	9 kg (21 lb)
Flammable anesthetic mixture	Not suitable for use in the presence of a flammable anesthetic mixture with air, oxygen, or nitrous oxide
Operating temperature	10 °C to 40 °C (50 °F to 104 °F)
Temperature limitation	-34 °C to 57 °C (-30 °F to 135 °F)
Humidity limitation	5% to 95% RH 35 °C (95 °F)
Power cable length	3.0 m (10 ft)

<sup>a</sup> All measurements are approximate

### Output Power Diagrams

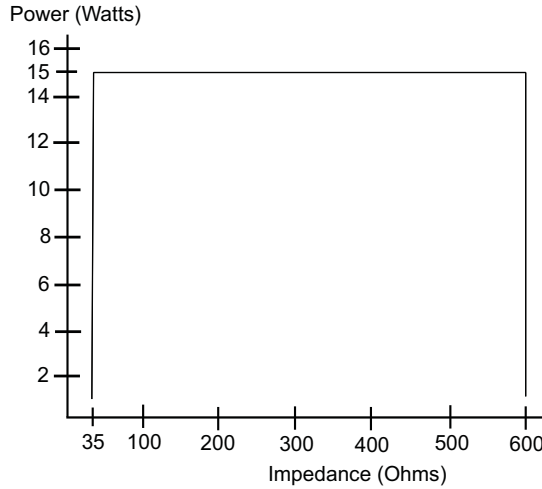

Figure 6-1. Output Power vs. Load

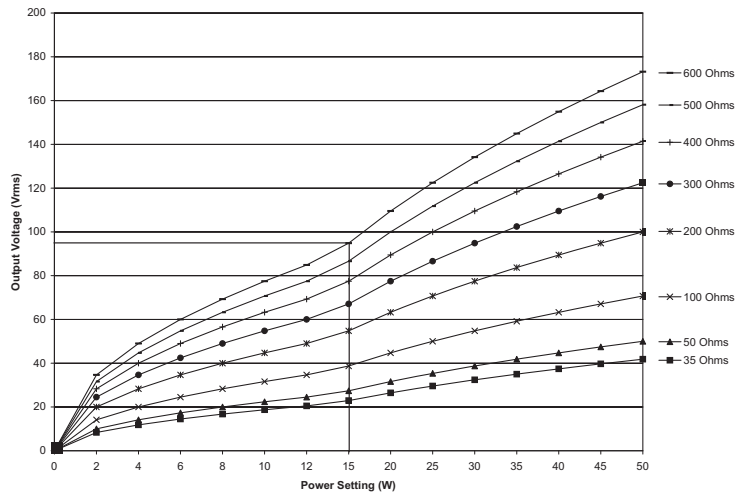

Figure 6-2. Output Voltage vs. Power Setting

**Note:** RF Generator is rated at 50 W, however, software algorithm limits maximum output to 15 W or 95 Vrms (each channel).

## Hand Piece

**Table 6-2.** Model 8929 Hand Piece Specifications<sup>a</sup>

Description	Specification
Sheath	Rigid with "bullet" tip
Sheath diameter	6.1 mm (18.5 French, .24 in)
Sheath length	24.7 cm (10 in) with 1 cm (.4 in) measuring marks
Overall length	38 cm (15 in)
Needle deployment angle	Needles exit at approximately 90°, posteriorly
Needle lengths	Six lengths (12, 14, 16, 18, 20, and 22 mm) (.47, .55, .63, .71, .79, and .87 in)
Temperature limitation	-34 °C to 57 °C (-30 °F to 135 °F)
Radio frequency cable length	2.7 m (9 ft)
Maximum RF voltage (per channel)	95 Vrms (at 15 W, 600 Ohms-software limit)

<sup>a</sup> All measurements are approximate

## Telescope

**Table 6-3.** Telescope Specifications<sup>a</sup>

Description	Specification
Overall length	42 cm (17 in)
Working length	36.5 cm (14 in)
Outer diameter	Fits 3.0 mm, rigid (.1 in)
View angle	0° <sup>b</sup> or <span style="border: 1px solid black; padding: 0 2px;">USA</span> 15° <sup>c</sup>
Light cord compatibility	Storz, Olympus, Wolf, or Circon/ACMI,

<sup>a</sup> All measurements are approximate

<sup>b</sup> Model 8099

<sup>c</sup> USA Model 8099TU15

100 | **Chapter 6**  
Device Specifications

### Return Electrode

**Table 6-4.** Model 8934 Return Electrode<sup>a</sup>

Description	Specification
Dimensions	10 cm W x 20 cm L (4 in W x 8 in L)
Materials	Polyethylene sponge, aluminum foil (no latex)
Cable length	2.7 m (9 ft)
Maximum RF voltage (per channel)	95 Vrms (at 15 W, 600 Ohms-software limit)

<sup>a</sup> All measurements are approximate

### Remote Foot Switch (optional)

**Table 6-5.** Model 60883 Foot Switch<sup>a</sup>

Description	Specification
Dimensions	13 cm W x 15 cm L (5 in W x 6 in L)
Cable length	4.6 m (15 ft)
Environmental conditions	IP 68, water resistant

<sup>a</sup> All measurements are approximate

## Electromagnetic Compatibility Declaration (EN60601-1-2)

**Table 6-6.** Electromagnetic Emissions

The <b>Model 8930 Radio Frequency Generator</b> is intended for use in the electromagnetic environment specified below. The customer or the user of the generator should ensure that it is used in such an environment.		
Emissions test	Compliance	Electromagnetic environment – guidance
Radio-frequency (RF) emissions CISPR 11	Group 2	The Model 8930 must emit electromagnetic energy in order to perform its intended function. Nearby electronic equipment may be affected.
RF emissions CISPR 11	Class A	The Model 8930 is suitable for use in all establishments other than domestic and those directly connected to the public low-voltage power supply network that supplies buildings used for domestic purposes.
	Not Applicable	The device is suitable for use in all establishments, including domestic establishments and those directly connected to the public low-voltage power supply network that supplies buildings used for domestic purposes.
Harmonic emissions EN 61000-3-2	Class A	The Model 8930 is suitable for use in all establishments, including domestic establishments and those directly connected to the public low-voltage power supply network that supplies buildings used for domestic purposes.
	Not Applicable	The device is suitable for use in all establishments other than domestic and those directly connected to the public low-voltage power supply network that supplies buildings used for domestic purposes.
Voltage fluctuations/flicker emissions EN 61000-3-3	Complies	The Model 8930 is suitable for use in all establishments, including domestic establishments and those directly connected to the public low-voltage power supply network that supplies buildings used for domestic purposes.
	Not Applicable	The device is suitable for use in all establishments other than domestic and those directly connected to the public low-voltage power supply network that supplies buildings used for domestic purposes.

102 | Chapter 6  
 Device Specifications

**Table 6-7.** Electromagnetic Immunity

The <b>Model 8930 Radio Frequency Generator</b> is intended for use in the electromagnetic environment specified below. The customer or the user of the generator should ensure that it is used in such an environment.			
Immunity Test	EN 60601 Test Level	Compliance Level	Electromagnetic Environment – Guidance
Electrostatic discharge (ESD): EN 61000-4-2	±2, ±4, ±6 kV contact ±2, ±4, ±8 kV air	±6 kV contact ±8 kV air	Floors should be wood, concrete or ceramic tile. If floors are covered with synthetic material, the relative humidity should be at least 30%.
Electrical fast transient/burst: EN 61000-4-4	±2 kV for power supply lines ±1 kV for input/output lines	±2 kV for power supply lines ±1 kV for input/output lines	Mains power quality should be that of a typical commercial or hospital environment.
Surge: EN 61000-4-5	±1 kV differential mode ±2 kV common mode	±1 kV differential mode ±2 kV common mode	Mains power quality should be that of a typical commercial or hospital environment.
Voltage dips, short interruptions and voltage variations on power supply input lines: EN 61000-4-11	<5% $U_T$ (>95% dip in $U_T$ ) for 0.5 cycle  40% $U_T$ (60% dip in $U_T$ ) for 5 cycles  70% $U_T$ (30% dip in $U_T$ ) for 25 cycles	<5% $U_T$ (>95% dip in $U_T$ ) for 0.5 cycle  40% $U_T$ (60% dip in $U_T$ ) for 5 cycles  70% $U_T$ (30% dip in $U_T$ ) for 25 cycles	Mains power quality should be that of a typical commercial or hospital environment. If the user of the device requires continued operation during power mains interruptions, it is recommended that the device be powered from an uninterruptible power supply or a battery.
Power frequency (50/60 Hz) magnetic field: EN 61000-4-8	3 A/m	3 A/m	Power frequency magnetic fields should be at levels characteristic of a typical location in a typical commercial or hospital environment.
<b>Note:</b> $U_T$ is the A.C. mains voltage prior to application of the test level.			

**Table 6-7.** Electromagnetic Immunity (continued)

The **Model 8930 Radio Frequency Generator** is intended for use in the electromagnetic environment specified below. The customer or the user of the generator should ensure that it is used in such an environment.

Immunity Test	EN 60601 Test Level	Compliance Level	Electromagnetic Environment–Guidance
Portable and mobile RF communications equipment should be used no closer to any part of the Model 8930, including cables, than the recommended separation distance calculated from the equation applicable to the frequency of the transmitter.			
			<b>Recommended separation distance</b>
Conducted RF EN 61000-4-6	3 Vrms 150 kHz to 80 MHz	3V	$d = 1.2\sqrt{P}$
Radiated RF EN 61000-4-3	3 V/m 80 MHz to 2.5 GHz	3 V/m	$d = 1.2\sqrt{P}$ 80 MHz to 800 MHz $d = 2.3\sqrt{P}$ 800 MHz to 2.5 GHz
Where $P$ is the maximum output power rating of the transmitter in watts (W) according to the transmitter manufacturer and $d$ is the recommended separation distance in meters (m).			
Field strengths from fixed RF transmitters, as determined by an electromagnetic site survey, <sup>a</sup> should be less than the compliance level in each frequency range. <sup>b</sup>			
Interference may occur in the vicinity of equipment marked with the following symbol: 			
<b>Notes:</b>			
<ul style="list-style-type: none"> <li>At 80 MHz and 800 MHz, the higher frequency range applies.</li> <li>These guidelines may not apply in all situations. Electromagnetic propagation is affected by absorption and reflection from structures, objects and people.</li> </ul>			
<sup>a</sup> Field strengths from fixed transmitters, such as base stations for radio (cellular/cordless) telephones and land mobile radios, amateur radio, AM and FM radio broadcast and TV broadcast cannot be predicted theoretically with accuracy. To assess the electromagnetic environment due to fixed RF transmitters, an electromagnetic site survey should be considered. If the measured field strength in the location in which the Model 8930 is used exceeds the applicable RF compliance level above, the Model 8930 should be observed to verify normal operation. If abnormal performance is observed, additional measures may be necessary, such as re-orienting or relocating the device.			
<sup>b</sup> Over the frequency range 150 kHz to 80 MHz, field strengths should be less than 3 V/m.			

104 | **Chapter 6**  
 Device Specifications

**Table 6-8.** Recommended separation distances between portable and mobile radio frequency (RF) communication equipment and the Model 8930 Radio Frequency Generator .

<p>The <b>Model 8930 Radio Frequency Generator</b> is intended for use in an electromagnetic environment in which radiated RF disturbances are controlled. The customer or the user of the generator can help prevent electromagnetic interference by maintaining a minimum distance between portable and mobile RF communications equipment (transmitters) and the generator as recommended below, according to the maximum output power of the communications equipment.</p>			
Rated maximum output power of Transmitter (W)	150 kHz to 80 MHz (m)	80 MHz to 800 MHz (m)	800 MHz to 2.5 GHz (m)
	$d = 1.2\sqrt{P}$	$d = 1.2\sqrt{P}$	$d = 2.3\sqrt{P}$
0.01	0.12	0.12	0.23
0.1	0.38	0.38	0.73
1	1.2	1.2	2.3
10	3.8	3.8	7.3
100	12	12	23
<p>For transmitters rated at a maximum output power not listed above, the recommended separation distance <math>d</math> in meters (m) can be estimated using the equation applicable to the frequency of the transmitter, where <math>P</math> is the maximum output power rating of the transmitter in watts (W) according to the transmitter manufacturer.</p>			
<p><b>Notes:</b></p> <ul style="list-style-type: none"> <li>At 80 MHz and 800 MHz, the separation distance for the higher frequency range applies.</li> <li>These guidelines may not apply in all situations. Electromagnetic propagation is affected by absorption and reflection from structures, objects, and people.</li> </ul>			
<p><b>⚠ Cautions:</b></p> <ul style="list-style-type: none"> <li>Do not use non-Medtronic components with Medtronic in-line-powered external devices. The use of non-Medtronic components may result in damage to Medtronic components, increased emissions, or decreased electromagnetic immunity of the Medtronic devices or systems.</li> <li>Do not use Medtronic in-line-powered external devices adjacent to, or stacked with, other electronic devices. Using Medtronic devices in these configurations may result in decreased electromagnetic immunity of the Medtronic devices or systems.</li> </ul>			
<p><b>RF Cable:</b> The Medtronic Prostiva RF Therapy Model 8929 radio frequency cable is approximately 2.7 m in length.</p>			

## Supplemental Information

# 7

**This chapter provides additional reference information.**

**Prostiva RF Therapy Worksheet 106**

**Periodic Inspection and Maintenance 109**

Radio Frequency Generator 109

Telescope 111

**Troubleshooting Checklist 112**

**HIPAA Security Rule Declaration 115**

106 | **Chapter 7**  
Prostiva RF Therapy Worksheet

## Prostiva RF Therapy Worksheet

Patient Name: \_\_\_\_\_ Date: \_\_\_\_\_

Patient ID #: \_\_\_\_\_

Age: \_\_\_\_\_

Doctor: \_\_\_\_\_

Facility: \_\_\_\_\_

Patient Temperature: \_\_\_\_\_

TRUS: yes no

Prostate Volume: \_\_\_\_\_ cm<sup>3</sup> or gm

Prostate Transverse Diameter (A): \_\_\_\_\_ mm

Prostatic Urethra Length (B): \_\_\_\_\_ cm

Needle Length: \_\_\_\_\_ mm

Anesthesia: \_\_\_\_\_

Number of treatment planes: \_\_\_\_\_

Middle Lobe Treated: yes no

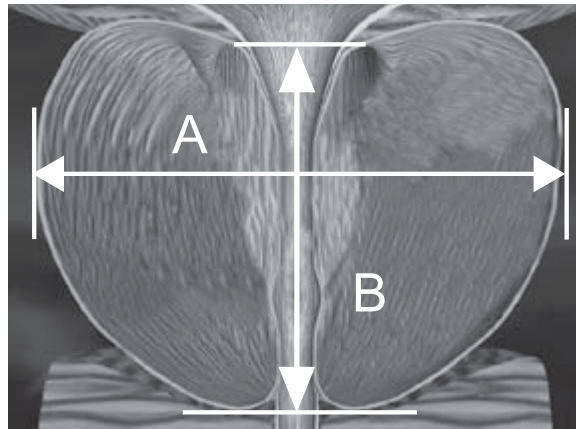

**Figure 7-1.** Prostate Measurement Example

**Supplemental Information** | 107  
Prostiva RF Therapy Worksheet

**Lesion Information**

**No. 1:** \_\_\_\_\_

Needle Length: \_\_\_\_\_

Target Temperature: \_\_\_\_\_

Comments: \_\_\_\_\_

**No. 2:** \_\_\_\_\_

Needle Length: \_\_\_\_\_

Target Temperature: \_\_\_\_\_

Comments: \_\_\_\_\_

**No. 3:** \_\_\_\_\_

Needle Length: \_\_\_\_\_

Target Temperature: \_\_\_\_\_

Comments: \_\_\_\_\_

**No. 4:** \_\_\_\_\_

Needle Length: \_\_\_\_\_

Target Temperature: \_\_\_\_\_

Comments: \_\_\_\_\_

**No. 5:** \_\_\_\_\_

Needle Length: \_\_\_\_\_

Target Temperature: \_\_\_\_\_

Comments: \_\_\_\_\_

**No. 6:** \_\_\_\_\_

Needle Length: \_\_\_\_\_

Target Temperature: \_\_\_\_\_

Comments: \_\_\_\_\_

108 | **Chapter 7**  
Prostiva RF Therapy Worksheet

**No. 7:** \_\_\_\_\_

Needle Length: \_\_\_\_\_

Target Temperature: \_\_\_\_\_

Comments: \_\_\_\_\_

**No. 8:** \_\_\_\_\_

Needle Length: \_\_\_\_\_

Target Temperature: \_\_\_\_\_

Comments: \_\_\_\_\_

## Periodic Inspection and Maintenance

### Radio Frequency Generator

Medtronic recommends that a qualified person who has adequate training, knowledge, and practical experience to perform the following periodic inspection and routine maintenance. These tasks should be performed at least once every 12 months.

Contact Medtronic about any items needing repair or replacement. Do not attempt to repair the radio frequency generator.

**Warning:** Do not use the radio frequency generator if it is damaged, is not functioning properly, or fails to meet an electrical safety check. Notify the appropriate personnel to ensure that the generator is removed from service and properly repaired. Contact Medtronic for service and do not attempt to repair the generator. Using a radio frequency generator that requires repair could cause serious injury or death to the patient, clinician, or others.

### Visual inspection

The following should be visually inspected:

- Check the system user guide and related technical manuals for legibility and completeness.
- Check that all the generator's labels are present and legible.
- Check that the generator case, video screen, controls, cables, and accessories show no signs of damage.
- Check the generator's fuses to verify compliance with rated current and breaking characteristics (refer to Table 6-1 on page 96). Remove the power cord, and then pull fuse compartment (above power connector) open with finger; close after inspecting.

## 110 | Chapter 7 Periodic Inspection and Maintenance

### Operating test

The following should be functionally tested:

- Set-up generator and turn on power to check the self-test diagnosis and the audible tone output.
- Configure the system and confirm that the radio frequency power shuts down when the return electrode is disconnected.

### Electrical safety test

Complete the following tests in accordance with the applicable section of the international standard IEC 60601-1:

- Test the protective earth resistance limit: 0.1 Ohms.
- Test the earth leakage current limit: .5 mA.
- Test the enclosure leakage current limit: .1 mA.

### Cleaning

When necessary, clean the radio frequency generator according to the following guidelines:

- Always unplug the generator before cleaning.
- Keep liquid, including the cleaning fluid, out of the generator's case and any openings.
- Do not use spray cleaner directly onto the generator.
- Do not use harsh or caustic chemical products to clean the generator.
- Clean the exterior case of the generator with a soft cloth lightly dampened with water.
- To clean the LCD screen, dilute a household water based glass cleaner to a 50/50 ratio with water and spray a small amount on a clean, soft cloth and gently wipe the screen.

**Supplemental Information** | 111  
Periodic Inspection and Maintenance

**Service**

The Prostiva RF Therapy Model 8930 Radio Frequency Generator has been carefully engineered, manufactured, and quality tested to provide trouble-free service. Contact your local Medtronic representative if service or repair is required. The applicable Medtronic offices are printed on the backcover.

If possible, please ship the generator back to Medtronic in its original shipping container. If the original container is not available, ask your local representative for instructions regarding packaging the generator for shipment.

Please write the generator serial number from the back of the device case on all correspondence.

Contact your local Medtronic representative for replacement parts such as cables and foot switches.

**Disposal**

At the end of its useful life, dispose of the generator in accordance with local environmental requirements.

**Telescope**

**Cleaning and Sterilization**

Before its first use, and before all subsequent uses, the telescope must be cleaned and sterilized.

Check the applicable light cable used with the telescope to ensure that there are no signs of damage to the insulation.

Refer to the appropriate telescope *Instructions for Use* for detailed instructions regarding the handling, cleaning and sterilization of the telescope.

## Troubleshooting Checklist

The following troubleshooting checklist is intended to augment the system user interface by providing some additional guidance to help you prevent problems encountered during treatment.

The action and prevention instructions in Table 7-1 are recommendations based on clinical experience. **The selection of the appropriate corrective action or continued treatment is in the clinician's sole medical judgment.**

**Table 7-1.** Troubleshooting Checklist

Symptom	Probable Cause	Actions	Prevention
<ul style="list-style-type: none"> <li>Impedance is greater than or equal to 180 <math>\Omega</math> (Ohms)</li> </ul>	<ul style="list-style-type: none"> <li>Shields may not be withdrawn</li> </ul>	<ul style="list-style-type: none"> <li>Check shields.</li> </ul>	<ul style="list-style-type: none"> <li>Ensure needles and shields are at appropriate lengths in accordance with the prescribed treatment protocol.</li> </ul>
	<ul style="list-style-type: none"> <li>Needles may be in capsule</li> </ul>	<ul style="list-style-type: none"> <li>Redeploy needles.</li> <li>Check needle length.</li> </ul>	<ul style="list-style-type: none"> <li>Check the ultrasound report for transverse measurement of the prostate.</li> <li>Consider possibility of an asymmetrical prostate and adjust needle length.</li> </ul>
	<ul style="list-style-type: none"> <li>Needle may be touching prostatic stone</li> </ul>	<ul style="list-style-type: none"> <li>Move needles 1-2 mm.</li> <li>Redeploy needle.</li> </ul>	<ul style="list-style-type: none"> <li>Check the ultrasound report for evidence and location of stones or unusual anatomical differences.</li> </ul>
	<ul style="list-style-type: none"> <li>Needles may be in subvascular adipose tissue</li> </ul>	<ul style="list-style-type: none"> <li>Continue with lesion. As tissue is ablated, cell will release water, which reduces impedance.</li> </ul>	<ul style="list-style-type: none"> <li>Be sure needles are accurately positioned.</li> </ul>

**Supplemental Information** | 113  
**Troubleshooting Checklist**

**Table 7-1.** Troubleshooting Checklist

Symptom	Probable Cause	Actions	Prevention
<ul style="list-style-type: none"> <li>Impedance is less than 80 <math>\Omega</math></li> </ul>	<ul style="list-style-type: none"> <li>Needle may be deployed in bladder or through bladder neck</li> <li>Needle may be in a vessel</li> </ul>	<ul style="list-style-type: none"> <li>Retract and redeploy needles and shields.</li> <li>Consider shortening needles.</li> </ul>	<ul style="list-style-type: none"> <li>Ensure needle deployment is 1 cm distal from the bladder neck.</li> </ul>
<ul style="list-style-type: none"> <li>Temperature increase on one needle is slower than normal</li> </ul>	<ul style="list-style-type: none"> <li>Needle may be touching prostatic stone</li> <li>Irrigation may still be on</li> <li>Needle may be in the bladder or blood vessel</li> </ul>	<ul style="list-style-type: none"> <li>Retract and redeploy needles and shields.</li> <li>Turn <b>off</b> irrigation.</li> <li>Check impedance.</li> </ul>	<ul style="list-style-type: none"> <li>Check ultrasound for evidence and location of stones.</li> <li>Check irrigation before ablation.</li> <li>Ensure needle deployment is 1 cm distal from the bladder neck.</li> </ul>
<ul style="list-style-type: none"> <li>Urethral temperature rise is consistent with one needle</li> </ul>	<ul style="list-style-type: none"> <li>Needles may be tracking across the urethra</li> </ul>	<ul style="list-style-type: none"> <li>Stop power delivery; retract and redeploy needles and shields.</li> </ul>	<ul style="list-style-type: none"> <li>Apply lateral pressure before needle deployment.</li> </ul>
<ul style="list-style-type: none"> <li>Red "overview" occludes vision/blocks irrigation channel</li> </ul>	<ul style="list-style-type: none"> <li>Blood clots over optics tip</li> </ul>	<ul style="list-style-type: none"> <li>Use a Luer lock syringe to flush via irrigation channel. This may remove larger blood clots with the hand piece sheath.</li> <li>Alternatively, unlock the rod lens and slowly retract from hand piece; gently slide rod lens in and out of hand piece to dislodge any blood clots</li> </ul>	<ul style="list-style-type: none"> <li>Avoid moving and repositioning of the hand piece as much as possible.</li> <li>Excessive movement may cause more trauma and bleeding.</li> <li>Increase flow rate of irrigation</li> <li>Irrigate between lesions to wash away blood.</li> </ul>
<ul style="list-style-type: none"> <li>"Black" vision on optics</li> </ul>	<ul style="list-style-type: none"> <li>Full bladder</li> </ul>	<ul style="list-style-type: none"> <li>Empty bladder.</li> </ul>	<ul style="list-style-type: none"> <li>Be sure bladder is appropriately drained.</li> </ul>
	<ul style="list-style-type: none"> <li>Broken optics</li> </ul>	<ul style="list-style-type: none"> <li>Check optics.</li> </ul>	<ul style="list-style-type: none"> <li>Handle optics carefully.</li> </ul>

114 | **Chapter 7**  
Troubleshooting Checklist

**Table 7-1.** Troubleshooting Checklist

Symptom	Probable Cause	Actions	Prevention
▪ Patient uncomfortable, feels hot sensation	▪ Full bladder	▪ Empty bladder.	▪ Be sure bladder is appropriately drained.
	▪ High urethral temperature	▪ Turn <b>on</b> irrigation for a few seconds.	▪ Maintain adequate shielding. Maintain adequate analgesic /anesthetic control.

## HIPAA Security Rule Declaration

### Introduction

The following information describes for Medtronic's customers in the United States (U.S.) the use and security of electronic protected health information (ePHI). The ePHI is defined in the Health Insurance Portability and Accountability Act, or HIPAA, Security Rule, 45 C.F.R. 165.514.

This information is intended to assist U.S. customers in safeguarding ePHI and complying with the requirements of the rule and other applicable requirements.

This information is not intended as a comprehensive or exhaustive list of issues and recommendations. Your organization's particular needs and security requirements may call for additional actions and controls than those stated here. Each organization must reach its own decisions on how to implement appropriate safeguards, and this information is intended to assist but not control that process.

### Model 8930 RF Generator

The Model 8930 RF Generator maintains within its memory data collected on a specific patient during the current procedure, but the data is not associated with any personally identifiable patient information. As the device does not store any personally identifiable patient information (no ePHI), it is not directly affected by the HIPAA Security Rule.

The only safeguard recommended is to appropriately protect the confidentiality of any data downloaded or printed from the device in the same manner as any other medical record, particularly after any patient identifier (such as a patient name or record label) has been added to the data or printout.

116 | **Chapter 7**  
Troubleshooting Checklist

# Device Warranties and End User License Agreement

## 8

**This chapter describes the device warranties and end user license agreement. The warranties apply only in the United States. Customers outside the United States should contact their local Medtronic representative for exact terms of the Limited Warranties.**

## Device Warranties

### Radio Frequency Generator

#### **IMPORTANT – EQUIPMENT LIMITED WARRANTY (U.S. Customers Only)**

- A. This Limited Warranty provides the following assurance to the purchaser of the Medtronic Prostiva® RF Therapy Generator (Model 8930), hereafter referred to as “Equipment”:
- (1) Should the Equipment fail to function within normal tolerances due to a defect in materials or workmanship within a period of one (1) year, commencing with the delivery of the Equipment to the purchaser, Medtronic will, at its option: (a) repair or replace any part or parts of the Equipment; (b) issue a credit to the purchaser equal to the Purchase Price, as defined in Subsection A(2), against the purchase of the replacement Equipment or (c) provide a functionally comparable replacement Equipment at no charge.
  - (2) As used herein, Purchase Price shall mean the lesser of the net invoiced price of the original, or current functionally comparable, or replacement Equipment.
- B. To qualify for Limited Warranty set forth in Section A(1), these conditions must be met:
- (1) The Equipment must be returned to Medtronic within thirty (30) days after discovery of the defect. (Medtronic may, at its option, repair the Equipment on site.)
  - (2) The Equipment must not have been repaired or altered outside of Medtronic’s facility in any way which, in the judgment of Medtronic, affects its stability and reliability.
  - (3) The Equipment must not have been subjected to misuse, abuse or accident.
  - (4) The Equipment must have been used in accordance with the labeling and instructions for use provided with the Equipment.
- C. This Limited Warranty is limited to its express terms. In particular:

**Device Warranties and End User License Agreement** | 119  
Device Warranties

- (1) Except as expressly provided by this Limited Warranty, MEDTRONIC IS NOT RESPONSIBLE FOR ANY MEDICAL EXPENSES OR ANY DIRECT, SPECIAL, INCIDENTAL OR CONSEQUENTIAL DAMAGES BASED ON ANY DEFECT, FAILURE OR MALFUNCTION OF THE EQUIPMENT TO FUNCTION WITHIN NORMAL TOLERANCES, WHETHER THE CLAIM IS BASED ON WARRANTY, CONTRACT NEGLIGENCE, STRICT LIABILITY, OR OTHER TORT OR OTHERWISE.
- (2) This Limited Warranty is made only to the purchaser who uses the Equipment. MEDTRONIC MAKES NO OTHER WARRANTY, EXPRESS OR IMPLIED, INCLUDING BUT NOT LIMITED TO, ANY IMPLIED WARRANTY OF MERCHANTABILITY OR FITNESS FOR A PARTICULAR PURPOSE, WHETHER ARISING FROM STATUTE, COMMON LAW, CUSTOM OR OTHERWISE. NO EXPRESS OR IMPLIED WARRANTY TO THE PATIENT SHALL EXTEND BEYOND THE PERIOD SPECIFIED IN A(1) ABOVE. THIS LIMITED WARRANTY SHALL BE THE EXCLUSIVE REMEDY AVAILABLE TO ANY PERSON.
- (3) The exclusions and limitations set out above are not intended to, and should not be construed so as to contravene mandatory provisions of applicable law. If any part or term of this Limited Warranty is held to be illegal, unenforceable or in conflict with applicable law by a court of competent jurisdiction, the validity of the remaining portions of the Limited Warranty shall not be affected, and all rights and obligations shall be construed and enforced as if this Limited Warranty did not contain the particular part or term held to be invalid. This Limited Warranty gives the purchaser specific legal rights. The purchaser may also have other rights which vary from state to state.
- (4) No person has any authority to bind Medtronic to any representation, condition or warranty except this Limited Warranty.

This Limited Warranty is provided by Medtronic, Inc., 710 Medtronic Parkway, Minneapolis, MN 55432-5604. It applies only in the United States. Areas outside the United States should contact their local Medtronic representative for exact terms of the Limited Warranty.

## Hand Piece

### **IMPORTANT NOTICE – DISPOSABLE LIMITED WARRANTY (U.S. Customers Only)**

- A. This Limited Warranty provides the following assurance to the purchaser of the Medtronic Prostiva® RF Hand Piece (Model 8929), Return Electrode (Model 8934) and Tubing System (Model 6101), hereafter referred to as the “Product”:
- (1) Should the Product fail to function within normal tolerances due to a defect in materials or workmanship prior to its “Use by” date, Medtronic will, at its option: (a) issue a credit to the purchaser equal to the Purchase Price, as defined in Subsection A(2), against the purchase of the replacement Product or (b) provide a functionally comparable replacement Product at no charge.
  - (2) As used herein, Purchase Price shall mean the lesser of the net invoiced price of the original, or current functionally comparable, or replacement Product.
- B. To qualify for Limited Warranty set forth in Section A(1), these conditions must be met:
- (1) The Product must be used prior to its “Use by” date.
  - (2) The Product must be returned to Medtronic within thirty (30) days after discovery of the defect and shall be the Property of Medtronic.
  - (3) The Product must not have been altered or subjected to misuse, abuse or accident.
  - (4) The Product must be used in accordance with the labeling and instructions for use provided with the Product.
- C. This Limited Warranty is limited to its express terms. In particular:
- (1) Except as expressly provided by this Limited Warranty, MEDTRONIC IS NOT RESPONSIBLE FOR ANY MEDICAL EXPENSES OR ANY DIRECT, SPECIAL, INCIDENTAL OR CONSEQUENTIAL DAMAGES BASED ON ANY DEFECT, FAILURE OR MALFUNCTION OF THE PRODUCT TO FUNCTION WITHIN NORMAL TOLERANCES, WHETHER THE CLAIM IS BASED ON WARRANTY, CONTRACT NEGLIGENCE, STRICT LIABILITY OR OTHER TORT OR OTHERWISE.

**Device Warranties and End User License Agreement** | 121  
Device Warranties

- (2) This Limited Warranty is made only to the purchaser who uses the Product. MEDTRONIC MAKES NO OTHER WARRANTY, EXPRESSED OR IMPLIED, INCLUDING BUT NOT LIMITED TO, ANY IMPLIED WARRANTY OF MERCHANTABILITY, OR FITNESS FOR A PARTICULAR PURPOSE, WHETHER ARISING FROM STATUTE, COMMON LAW, CUSTOM OR OTHERWISE. NO EXPRESS OR IMPLIED WARRANTY TO THE PATIENT SHALL EXTEND BEYOND THE PERIOD SPECIFIED IN A(1) ABOVE. THIS LIMITED WARRANTY SHALL BE THE EXCLUSIVE REMEDY AVAILABLE TO ANY PERSON.
- (3) The exclusions and limitations set out above are not intended to, and should not be construed so as to contravene mandatory provisions of applicable law. If any part or term of this Limited Warranty is held to be illegal, unenforceable or in conflict with applicable law by a court of competent jurisdiction, the validity of the remaining portions of the Limited Warranty shall not be affected, and all rights and obligations shall be construed and enforced as if this Limited Warranty did not contain the particular part or term held to be invalid. This Limited Warranty gives the purchaser specific legal rights. The purchaser may also have other rights which vary from state to state.
- (4) No person has any authority to bind Medtronic to any representation, condition or warranty except this Limited Warranty.

This Limited Warranty is provided by Medtronic, Inc., 710 Medtronic Parkway, Minneapolis, MN 55432-5604. It applies only in the United States. Areas outside the United States should contact their local Medtronic representative for exact terms of the Limited Warranty.

## Telescope

### **IMPORTANT NOTICE – EQUIPMENT LIMITED WARRANTY (U.S. Customers Only)**

- A. This Limited Warranty provides the following assurance to the purchaser of the Medtronic Prostiva® RF Therapy Telescope (Model 8099 or USA Model 8099TU15), hereafter referred to as “Equipment”:
- (1) Should the Equipment fail to function within normal tolerances due to a defect in materials or workmanship within a period of 90 days, Medtronic will, at its option: (a) repair or replace any part or parts of the Equipment; (b) issue a credit to the purchaser equal to the Purchase Price, as defined in Subsection A(2), against the purchase of the replacement Equipment or (c) provide a functionally comparable replacement Equipment at no charge.
  - (2) As used herein, Purchase Price shall mean the lesser of the net invoiced price of the original, or current functionally comparable, or replacement Equipment.
- B. To qualify for Limited Warranty set forth in Section A(1), these conditions must be met:
- (1) The Equipment must be returned to Medtronic within thirty (30) days after discovery of the defect. (Medtronic may, at its option, repair the Equipment on site).
  - (2) The Equipment must not have been repaired or altered outside of Medtronic’s facility in any way which, in the judgment of Medtronic, affects its stability and reliability.
  - (3) The Equipment must not have been subjected to misuse, abuse or accident.
  - (4) The Equipment must have been used in accordance with the labeling and instructions for use provided with the Equipment.
- C. This Limited Warranty is limited to its express terms. In particular:

**Device Warranties and End User License Agreement** | 123  
Device Warranties

- (1) Except as expressly provided by this Limited Warranty, MEDTRONIC IS NOT RESPONSIBLE FOR ANY MEDICAL EXPENSES OR ANY DIRECT, SPECIAL, INCIDENTAL OR CONSEQUENTIAL DAMAGES BASED ON ANY DEFECT, FAILURE OR MALFUNCTION OF THE EQUIPMENT TO FUNCTION WITHIN NORMAL TOLERANCES, WHETHER THE CLAIM IS BASED ON WARRANTY, CONTRACT NEGLIGENCE, STRICT LIABILITY, OR OTHER TORT OR OTHERWISE.
- (2) This Limited Warranty is made only to the purchaser who uses the Equipment. MEDTRONIC MAKES NO OTHER WARRANTY, EXPRESSED OR IMPLIED, INCLUDING BUT NOT LIMITED TO, ANY IMPLIED WARRANTY OF MERCHANTABILITY, OR FITNESS FOR A PARTICULAR PURPOSE, WHETHER ARISING FROM STATUTE, COMMON LAW, CUSTOM OR OTHERWISE. NO SUCH WARRANTY TO THE PURCHASER SHALL EXTEND BEYOND THE PERIOD SPECIFIED IN A(1) ABOVE. THIS LIMITED WARRANTY SHALL BE THE EXCLUSIVE REMEDY AVAILABLE TO ANY PERSON.
- (3) The exclusions and limitations set out above are not intended to, and should not be construed so as to contravene mandatory provisions of applicable law. If any part or term of this Limited Warranty is held to be illegal, unenforceable or in conflict with applicable law by a court of competent jurisdiction, the validity of the remaining portions of the Limited Warranty shall not be affected, and all rights and obligations shall be construed and enforced as if this Limited Warranty did not contain the particular part or term held to be invalid. This Limited Warranty gives the purchaser specific legal rights. The purchaser may also have other rights which vary from state to state.
- (4) No person has any authority to bind Medtronic to any representation, condition or warranty except this Limited Warranty.

This Limited Warranty is provided by Medtronic, Inc., 710 Medtronic Parkway, Minneapolis, MN 55432-5604. It applies only in the United States. Areas outside the United States should contact their local Medtronic representative for exact terms of the Limited Warranty.

## End User License Agreement

### Wind River Run-Time Module End User License Agreement

The following applies to the embedded software operating system used in this product.

**THIS END USER LICENSE AGREEMENT** runs from Medtronic, Inc. (“Medtronic”), the seller of the Model 8930 RF Generator (“Generator”), to the purchaser/end user of the Generator (“You”) concerning the Wind River Run-Time Module (the “Module”) developed and licensed by Wind River Systems, Inc. (“Wind River”) and installed on the Generator:

1. **Agreement to License.** By using the Generator, You agree to the terms of this End User License Agreement. If You do not agree to these terms, do not use the Generator and contact Medtronic for product return instructions.
2. **Prohibited Acts and Users.** The Module may be restricted as to export under the United States Export Administration Regulations, in which case the Module may not be exported or re-exported to any country to which the United States embargoes goods. In addition, the Module may not be transferred to persons on the Table of Denial Orders, the Entity List, or the List of Specially Designated Nationals. By using the Module, You are certifying to Medtronic that You are not a national of any country to which the United States embargoes goods and that You are not a person on the Table of Denial Orders, the Entity List, or the List of Specially Designated Nationals.
3. **Grant of License.** Except as stated under Prohibited Acts and Users above, Medtronic grants You the following rights provided You comply with the terms of this Agreement:
  - a. You may install, use and run one (1) copy of the Module in order to operate the Generator.
  - b. All other rights in and to the Module are reserved to Medtronic and Wind River, except as specifically provided in this Agreement. Neither the purchase of a Generator on which the Module is installed nor anything in this Agreement transfers any rights in or to the Module to You (other than a right to a license under the terms and conditions set forth herein), and You agree that ownership rights in the Module remain with Wind River and its licensors.

**Device Warranties and End User License Agreement** | 125  
End User License Agreement

4. **Transfer of License.** Except as stated under Prohibited Acts and Users above, You may transfer Your rights under this Agreement solely to a purchaser of the Generator from You, provided that You may only transfer this license as to one (1) copy of the Module, and further provided that the purchaser must agree to the terms of this Agreement in order to receive any rights under it. If the purchaser does not agree to the terms of this Agreement, the purchaser may not use the Module or the Generator and must return them to You. You may not transfer any rights under this Agreement apart from a sale of the Generator.
5. **Software Upgrades.** Medtronic and/or Wind River may, from time to time, in their sole and complete discretion, provide You upgrades to the Module. You have no right to any upgrades to the Module even if upgrades exist or are provided to other users such as purchasers of more recent Generators or Modules.
6. **Bugs, Fixes and Version Releases.** All software including the Module has the potential for anomalies (collectively, "Bugs") that may occasionally interfere with the normal operation of the Module and/or the Generator, and may even result in having to restart the Generator, business interruption, loss of data or other consequences. Bugs are an inherent part of software operation, may occur from time to time in using the Generator and the Module, and do not constitute a product defect or breach of any warranty provided with the Generator. Medtronic and Wind River expressly disclaim any obligation to repair Bugs or to issue to You software fixes or version updates (collectively, "Fixes"), even if Fixes exist or are provided to other users such as purchasers of more recent Generators or Modules. Medtronic and/or Wind River may provide You Fixes in their sole and complete discretion.
7. **External Interferences.** If the Generator is connected to any external electrical or communication system, including a computer or telephone network or system, the Generator and/or the Module may be adversely affected by interference or other harm caused by such external systems including without limitation viruses, worms, Trojan horses, other malware or other harmful codes, signals or impulses (collectively, "External Interferences"). Neither Medtronic nor Wind River is responsible for any harm or damage caused to the Generator or Module by such External Interferences.

126 | **Chapter 8**  
End User License Agreement

8. **Prohibition of Modifications or Reverse Engineering.** You may not modify, reverse engineer, decompile or disassemble the Module, or otherwise attempt to view or derive the source code for the Module. Any such action on Your part automatically and without notice voids Your rights under this Agreement and You must immediately and without demand return the Generator and all copies or derivatives of the Module to Medtronic.
9. **Archival Copy.** You may make one (1) archival or backup copy of the Module for security and integrity purposes, provided that such copy is made in accordance with Your standard archival or backup policies and practices, and provided further that such copy of the Module may only be used for restoring the Module on the Generator in the event of damage to or failure of the Module.
10. **Prohibition on Sublicensing or Distribution.** You may not sublicense or distribute the Module to any other person or entity.
11. **Disclaimer of Warranties.** TO THE MAXIMUM EXTENT PERMITTED BY APPLICABLE LAW, MEDTRONIC AND WIND RIVER PROVIDE THE MODULE AND SUPPORT SERVICES (IF ANY) AS IS AND WITH ALL FAULTS, AND HEREBY DISCLAIM ALL WARRANTIES AND CONDITIONS, EITHER EXPRESS, IMPLIED OR STATUTORY, INCLUDING, BUT NOT LIMITED TO, ANY IMPLIED WARRANTIES OR CONDITIONS OF MERCHANTABILITY, OF FITNESS FOR A PARTICULAR PURPOSE, OF LACK OF VIRUSES, OF ACCURACY OR COMPLETENESS OF RESPONSES, OF RESULTS, AND OF LACK OF NEGLIGENCE OR LACK OF WORKMANLIKE EFFORT, ALL WITH REGARD TO THE MODULE. ALSO, THERE IS NO WARRANTY OR CONDITION OF TITLE, QUIET ENJOYMENT, QUIET POSSESSION, CORRESPONDENCE TO DESCRIPTION, OR NON-INFRINGEMENT, WITH REGARD TO THE MODULE.

**Device Warranties and End User License Agreement** | 127  
End User License Agreement

12. **Exclusion of Incidental, Consequential and Certain Other Damages.** TO THE MAXIMUM EXTENT PERMITTED BY APPLICABLE LAW, IN NO EVENT SHALL MEDTRONIC OR WIND RIVER BE LIABLE FOR ANY SPECIAL, INCIDENTAL, INDIRECT, OR CONSEQUENTIAL DAMAGES WHATSOEVER (INCLUDING, BUT NOT LIMITED TO, DAMAGES FOR LOSS OF PROFITS OR CONFIDENTIAL OR OTHER INFORMATION, FOR BUSINESS INTERRUPTION, FOR PERSONAL INJURY, FOR LOSS OF PRIVACY, FOR FAILURE TO MEET ANY DUTY INCLUDING OF GOOD FAITH OR OF REASONABLE CARE, FOR NEGLIGENCE, AND FOR ANY OTHER PECUNIARY OR OTHER LOSS WHATSOEVER) ARISING OUT OF OR IN ANY WAY RELATED TO THE USE OF OR INABILITY TO USE THE MODULE, THE PROVISION OF OR FAILURE TO PROVIDE SUPPORT SERVICES (IF ANY) PERTAINING TO THE MODULE, OR OTHERWISE UNDER OR IN CONNECTION WITH ANY PROVISION OF THIS AGREEMENT, EVEN IN THE EVENT OF THE FAULT, TORT (INCLUDING NEGLIGENCE), STRICT LIABILITY, BREACH OF CONTRACT OR BREACH OF WARRANTY (IF ANY) OF MEDTRONIC OR WIND RIVER, AND EVEN IF MEDTRONIC OR WIND RIVER HAS BEEN ADVISED OF THE POSSIBILITY OF SUCH DAMAGES. SOME STATES/JURISDICTIONS DO NOT ALLOW THE EXCLUSION OR LIMITATION OF INCIDENTAL OR CONSEQUENTIAL DAMAGES, SO THE ABOVE LIMITATIONS OR EXCLUSIONS MAY NOT APPLY TO YOU.
13. **Limitation of Liability and Remedies.** Notwithstanding any damages that You might incur for any reason whatsoever (including, without limitation, all damages referenced above and all direct or general damages), the entire liability of Medtronic and Wind River under any provision of this Agreement and Your exclusive remedy for all of the foregoing (except for any remedy of repair or replacement elected by Medtronic with respect to any breach of any written warranty provided with the Generator) shall be limited to U.S. \$100.00 in total. The foregoing limitations, exclusions and disclaimers (including Sections 11 and 12 above) shall apply to the maximum extent permitted by applicable law, even if any remedy fails its essential purpose.

128 | **Chapter 8**  
End User License Agreement

14. **Applicable Law.** This Agreement is governed by the laws of the State of Minnesota, exclusive of its choice of law rules.
15. **Severability.** If any part of this Agreement is held to be illegal, unenforceable or in conflict with applicable law by a court of competent jurisdiction, the validity of the remaining portions of this Agreement, and all rights and obligations shall be construed and enforced as if this Agreement did not contain the particular part held invalid.
16. **Third Party Beneficiaries.** Wind River and its licensors are third party beneficiaries of this Agreement and the provisions relating to the Module are made expressly for the benefit of, and are enforceable by, Wind River and its licensors.
17. **Entire Agreement.** This Agreement is the entire agreement between You and Medtronic relating to the Module and the support services (if any) and it supersedes all prior or contemporaneous oral or written communications, proposals and representations with respect to the Module or any other subject matter covered by this Agreement. No person has authority to bind Medtronic or Wind River to any representation, condition or warranty contrary or in addition to the terms of this Agreement, except as set forth in any written warranty supplied by Medtronic for the Generator.

**Sales offices:**

**Asia:** Medtronic International Ltd.  
Tel. 02891-4068  
Fax 02591-0313

Medtronic Asia Ltd.  
Tel. (02)-548-1148  
Fax (02)-518-4786

**Australia:** Medtronic Australasia Pty. Ltd.  
97 Waterloo Road  
North Ryde NSW 2113  
Australia  
Tel. +61-2-9857-9000  
Fax +61-2-9878-5100  
Toll-free 1-800-668-670

**Austria:** Medtronic Österreich GmbH  
Tel. (01)-240440  
Fax (01)-24044-100

**Belgium:** Medtronic Belgium S.A.  
Tel. 02-456-0900  
Fax 02-460-2667

**Canada:** Medtronic of Canada Ltd.  
Tel. (1905)-826-6020  
Fax (1905)-826-6620

**Czech Republic:** Medtronic Czechia s.r.o.  
Tel. 2-965-795-80  
Fax 2-965-795-89

**Denmark:** Medtronic Danmark A/S  
Tel. 45-32-48-18-00  
Fax 45-32-48-18-01

**Finland:** Medtronic Finland OY/LTD  
Tel. (09)-755-2500  
Fax (09)-755-25018

**France:** Medtronic France S.A.S.  
Tel. 01-5538-1700  
Fax 01-5538-1800

**Germany:** Medtronic GmbH  
Tel. (02159)-81490  
Fax (02159)-8149100

**Greece:** Medtronic Hellas S.A.  
Tel. 210-67-79-099  
Fax 210-67-79-399

**Hungary:** Medtronic Hungária Kft.  
Tel. 1-889-06-00  
Fax 1-889-06-99

**Ireland:** Medtronic Ireland Ltd.  
Tel. (01)-890-6522  
Fax (01)-890-7220

**Italy:** Medtronic Italia SpA  
Tel. 02-241371  
Fax 02-241381

Tel. 06-328141  
Fax 06-3215812

**Japan:** Medtronic Japan  
Tel. 3-6430-2011  
Fax 3-6430-7140

**Latin America:** Medtronic, Inc.  
Tel.(1305)-500-9328  
Fax (1786)-709-4244

**The Netherlands:** Medtronic B.V.  
Tel. (045)-566-8000  
Fax (045)-566-8668

**Norway:** Medtronic Norge AS  
Tel. 67-10-32-00  
Fax 67-10-32-10

**Poland:** Medtronic Poland Sp. z.o.o.  
Tel. (022)-465-69-00  
Fax (022)-465-69-17

**Portugal:** Medtronic Portugal, Lda.  
Tel. 21-724-5100  
Fax 21-724-5199

**Russia:** Medtronic Russia  
Tel. (8495) 580-7377  
Fax (8495) 580-7378

**Slovakia:** Medtronic Slovakia, o.z.  
Tel. 0268 206 911  
Fax 0268 206 999

**Spain:** Medtronic Ibérica, S.A.  
Tel. 91-625-0400  
Fax 91-650-7410

**Sweden:** Medtronic AB  
Tel. 08-568-585-00  
Fax 08-568-585-01

**Switzerland:** Medtronic (Schweiz) AG  
Tel. 031-868-0100  
Fax 031-868-0199

**U.K.:** Medtronic U.K. Ltd  
Tel. 01923-212213  
Fax 01923-241004

**USA:** Medtronic, Inc.  
Tel. (1-763)-505-5000  
Toll-free: (1-800)-328-0810  
Fax (1-763)-505-1000



# Medtronic

*Alleviating Pain · Restoring Health · Extending Life*

**Manufacturer** 

Medtronic, Inc.  
710 Medtronic Parkway  
Minneapolis, MN 55432-5604  
USA  
Internet: [www.medtronic.com](http://www.medtronic.com)  
Tel. 1-763-505-5000  
Fax 1-763-505-1000

**Authorized Representative**

EC	REP
----	-----

  
**in the European Community**

**Medtronic B.V.**  
Earl Bakkenstraat 10  
6422 PJ Heerlen  
The Netherlands  
Tel. 31-45-566-8000  
Fax 31-45-566-8668

**Europe/Africa/Middle East  
Headquarters**

Medtronic International Trading Sàrl  
Route du Molliau 31  
Case Postale 84  
CH-1131 Tolochenaz  
Switzerland  
Internet: [www.medtronic.com](http://www.medtronic.com)  
Tel. 41-21-802-7000  
Fax 41-21-802-7900

**Asia-Pacific**

Medtronic International Ltd.  
Suite 1602 16/F, Manulife Plaza  
The Lee Gardens, 33 Hysan Avenue  
Causeway Bay  
Hong Kong  
Tel. 852-2891-4068  
Fax 852-2591-0313

Contacts for specific countries are listed inside  
this cover.



\* M A 0 7 4 4 5 A 0 0 7 \*

© Medtronic, Inc. 2010  
All Rights Reserved  
MA07445A007