

# Targis<sup>®</sup>

## Instructions for Use

**Targis<sup>®</sup> System**  
**Control Unit, Model 4000 Series**  
**Targis<sup>®</sup> Microwave Delivery System (MDS)**  
**Rectal Thermosensing Unit (RTU)**  
**Coolant Bag**

*CAUTION: Federal (U.S.A.) law restricts this device to sale by or on the order of a physician trained and/or experienced in the use of this device as outlined in the required training program.*

*CAREFULLY READ AND UNDERSTAND ALL INSTRUCTIONS, INDICATIONS, WARNINGS, PRECAUTIONS, AND DIRECTIONS FOR USE PRIOR TO USING ANY TARGIS<sup>®</sup> COMPONENT OR THE CONTROL UNIT. FAILURE TO DO SO COULD RESULT IN COMPROMISED PATIENT SAFETY, PATIENT COMPLICATIONS AND/OR INSUFFICIENT TREATMENT.*

### Indications for Use

The Urologix<sup>®</sup> Targis System is a non-surgical device intended to relieve symptoms and obstruction associated with Benign Prostatic Hyperplasia (BPH) and is indicated for men with prostatic urethra lengths of 3 to 5 cm (model number TA1121D) or 2.5 to 3.5 cm (model number TA13211D).

### Targis System Description

The Targis System is comprised of a Control Unit which produces the microwave energy and monitors all aspects of the Targis procedure, an MDS (treatment catheter) which delivers the microwave energy to the targeted prostatic tissue, an RTU which measures rectal temperatures during the Targis procedure and a Coolant Bag which provides a reservoir of sterile coolant water to the MDS. The Targis MDS is used as part of the Targis System to treat men with prostatic urethra lengths as indicated on the MDS label and as measured from the bladder neck to the verumontanum.

### Contraindications for Targis Treatment

- *Patients with a prostatic urethra <2.5 cm in length, measured from the bladder neck to the verumontanum*
- *Patients with urinary sphincter or any implant (metallic or non-metallic) which is within 1.5 inches (38 mm) of the prostatic urethra*
- *Patients with urethral stricture (unable to pass 22 F urethroscope)*
- *Patients with peripheral arterial disease with intermittent claudication or Leriche's Syndrome (i.e. claudication of the buttocks or perineum)*
- *Patients who have undergone pelvic radiation therapy*
- *Patients with implanted active devices, including pacemakers or defibrillators, within 2.6 inches (6.5 cm) of the prostatic urethra.*

### Warnings

The Targis procedure has inherent associated risks of complications (refer to Adverse Events and Complications). The Targis System and components should not be used in any way other than the intended and indicated use and according to the Instructions For Use.

### Precautions

Only those physicians who have been thoroughly trained on the operation of the Targis System and the Targis procedure should deliver the Targis procedure.

The Targis procedure must not be initiated without assurance that the MDS is properly positioned in the patient. The correct positioning of the MDS must always be checked by ultrasound imaging prior to commencing treatment. **Improper placement or orientation of the MDS may lead to procedure failures or heating damage of non-target tissues such as the bladder neck, external sphincter or penile urethra.**

The Targis procedure must not be initiated until an enema has been given and the RTU is properly placed into the patient's rectum and inflated.

For patients with active implanted devices located greater than 2.6 inches (6.5 cm) from the prostatic urethra, it is recommended that non-cardiac devices be turned OFF during treatment with the Targis system, if possible (e.g. active implanted devices used in the treatment of pain or incontinence), to lessen the likelihood of adverse interaction caused by electromagnetic interference. If possible, active implanted devices that must remain ON should be programmed to the bipolar configuration. Implanted cardioverter defibrillators should be set to monitor only mode during therapy. Regardless of whether active implanted devices > 2.6 inches (6.5 cm) from the prostatic urethra can be turned OFF, the patient should be monitored during Targis treatment for possible interactions. In the unlikely event of an active implanted device programming change, the device should be interrogated following treatment with the Targis system.

It is important that the patient **not be over sedated**. This may compromise his ability to communicate pain.

All components of the Targis System must be used in a manner consistent with the instructions set forth in their respective Instructions For Use insert and the Targis System User Manual. Failure to do so may result in insufficient treatment or increased risk of injury or infection to the patient.

Use of the Targis System results in the deposition of microwave energy within the patient's prostate and in adjacent regions of the body. Some animal studies in the literature suggest that there may be as yet unknown health effects from exposure to microwave radiation, including an increased incidence of tumors. Although it is not possible to extrapolate these studies to humans, they suggest that unnecessary microwave radiation exposure should be avoided.

At least 20 cm of ventilation clearance must be provided around the base of the Control Unit.

The Urologix Targis system emits a small amount of electromagnetic energy during a procedure. Urologix recommends that all electronic medical devices be kept at a minimum distance of 1.0 meter from the Targis System when performing a treatment. However, a 1.0 meter separation of electronic medical equipment from the Targis System does not guarantee that operation of other devices will not be impacted. The effect of this electromagnetic energy on all equipment can not be predicted due to age and quality of maintenance. The performance of each piece of equipment operated near the Targis system, during a procedure, must be evaluated for degradation.

Since microwave energy can travel through walls, ceilings, and floors to affect other devices, it is important to understand that the 1 meter safety distance applies not only to the treatment room, but also to all adjacent rooms in the building, including the rooms above and below the treatment room.

Do not operate the Targis system near equipment that emits electromagnetic energy, unless the effect on the Targis system has been evaluated and no degradation of performance was found.

The national standard ANSI/IEEE C95.1 - 1999 Edition (Safety Levels with Respect to Human Exposure to Radio Frequency Electromagnetic Fields) recommends a maximum stray field exposure level for whole body exposure of 3 mW/cm<sup>2</sup>, as averaged for any six minute period. The maximum radiated field, at full power, from the Targis Control Unit patient cable and catheter, at five centimeters, is 2.1 mW/cm<sup>2</sup>. Urologix recommends that the operator maintain a minimum distance to five centimeters from the patient cable and exposed portions of the catheter during the procedure.

Operate the Control Unit and connected devices only in clinical environments where the electrical installation is in accordance with international standard DIN VDE 0107; and the national standard, ANSI/NFPA 70. The equipment must be connected to a fully tested, hospital grade power outlet with adequate grounding.

The Control Unit must be plugged into the appropriate voltage outlet.

The electrical equipment inside the Targis System uses voltages which are capable of causing serious injury or death from electric shock. To avoid this hazard, operators must never open the housing of the Control Unit.

**Power Requirements**

*Supply:* European Version: 220/240 V  $\pm 10\%$  (8 A) Single phase 50 or 60 Hz  
US Version: 110/120 V  $\pm 10\%$  (15 A) Single phase 50 or 60 Hz  
Japanese Version: 100 V  $\pm 10\%$  (15 A) Single phase 50 or 60 Hz

*Connections:* Hospital Grade plug

**For further safety information, refer to the TARGIS SYSTEM USER MANUAL.**

The safety and effectiveness of the Targis procedure has not been established in patients with the following conditions:

- *Clinical or histological evidence of prostatic cancer or bladder cancer*
- *Interest in preservation of future fertility*
- *Post Void Residual (PVR) > 350 mL*
- *Previous pelvic surgery*
- *Previous rectal surgery (other than hemorrhoidectomy)*
- *Obstructing median lobe enlarged out of proportion to the rest of the prostate and protruding significantly into the bladder, sometimes referred to as a "ball valve" median lobe.*
- *Active urinary tract infection*
- *Prostatic urethra > 5 cm in length as measured from the bladder neck to the verumontanum*
- *Gross hematuria not due to BPH*
- *Prior prostatic surgery (excluding balloon dilation)*
- *Coexisting illness or specific obstructive symptoms found to be caused by any of the following conditions:*
  - Neurologic bladder disorders*
  - Prostate volume greater than 100 cc*
  - Bladder neck contracture*
  - Urinary sphincter abnormalities*
  - Bladder stones*
  - Evidence of bacterial prostatitis*
  - Renal impairment*
  - Coagulation disorders*

A thorough physical exam should be performed on patients prior to initiation of the Targis procedure.

Patients who have received treatment with the Targis System should be followed on an annual basis since the treatment does not result in complete destruction of the prostate.

The prostate specific antigen (PSA) levels will increase significantly following treatment. This increase can be up to 10 times (1000 percent) higher at 1 week and will decrease back to approximate normal levels by 6 weeks following the Targis treatment. The use of PSA testing during this period will be unreliable. Physicians are cautioned to measure the serum PSA level before treatment for future comparisons. PSA levels should return to baseline by 3 months following Targis treatment and may once again be used as a diagnostic test.

Attention by a qualified physician is required during the use of the Targis System. The Control Unit display must be monitored and controlled during the course of a treatment session to make sure that the MDS and rectal temperatures are within prescribed treatment parameters. Failure to monitor and deliver the Targis procedure per recommendations by Urologix may lead to decreased patient safety and/or reduced clinical effectiveness.

The Targis MDS and coolant bag are intended for one time use only. DO NOT resterilize and/or reuse them as this will likely result in compromised device performance and increased risk of injury or infection to a patient.

The Targis components must not be used with any other system.

Do not use an MDS if it appears to be damaged.

Use the MDS prior to the "use before" date specified on the package.

Care should be taken in handling all components of the Targis System to avoid damage that may lead to subsequent failure of the component or procedure.

Because the Targis procedure elevates intraprostatic tissue temperature causing tissue damage that may result in acute urinary retention, the patient may be catheterized for 2 to 5 days (median 3 days) following the procedure, and it is advisable that anti-inflammatory and antibiotic medications be prescribed for 3-5 days.

As patient responses to the Targis procedure are variable, the patient should be evaluated by their physician following treatment.

Failure to maintain the equipment may result in exposure of the patient and/or the operator to excessive microwave energy.

## **Adverse Events and Complications**

Most complications occurred shortly after treatment and were transient.

In the United States, multi-center prospective studies of the Targis procedure, 206 patients were treated and followed for complications, complaints and observations. The following table shows the clinical adverse events and complications that were possibly, probably and definitely related to the Targis procedure. An asterisk (\*) denotes events which were temporary or minor, requiring minimal or no medical intervention. Study investigators were required to notify Urologix of any complications which may have developed as a direct result of the Targis procedure. The following table is for the patients in the 60 minute vs. the 28.5 minute study. In the case of pain or discomfort during sexual activity, urgency, nocturia and urethral strictures, the rates for the 28.5 minute treatment are very similar to the original clinical study data.

After excluding post treatment conditions that are associated with BPH itself (i.e., dysuria, interrupted flow, sensation of not emptying bladder, frequency, hesitancy, urgency, post void dribbling, weak stream and nocturia), the complication rates for most categories are lower for the 28.5 minute treatment. These lower rates include: temporary or partial loss of ejaculate; hemospermia; prostatic urethral damage; temporary acute incontinence; bladder trabeculation; severe pain during treatment; blood pressure changes during treatment; hospitalization in general related to treatment; complete loss of ejaculate; persistent erectile

dysfunction; and epididymitis. The categories in which adverse events were found to be higher are rectal irritation, pain or discomfort during sexual activity, urinary tract infection, transient erectile dysfunction, and urethral stricture.

	<b><u>60 min</u></b>	<b><u>28.5 min</u></b>
Post-treatment catheterization	91.1%*	89.6%*
0	8.9%*	10.4%*
1-4 days	62.2%*	62.5%*
5-7 days	15.6%*	12.5%*
8-27 days	13.3%*	14.6%*
Mild hematuria	65.2%*	58.3%*
Dysuria	47.8%*	52.1%*
Clots in urine	47.8%*	43.8%*
Temporary or partial ejaculate loss	45.7%*	20.8%*
Pain or irritation in the groin or pelvis	41.3%*	31.3%*
Bladder spasms	39.1%*	33.3%*
Hemospermia	32.6%*	22.9%*
Prostatic urethra damage	30.4%*	20.8%*
Rectal irritation	23.9%*	39.6%*
Temporary acute incontinence	21.7%*	14.6%*
Interrupted flow	13.0%*	18.8%*
Sensation of not emptying bladder	13.0%*	16.7%*
Bladder trabeculation	10.9%*	6.3%*
Severe pain during treatment	8.9%*	2.1%*
Pain or discomfort during sexual activity	8.7%*	14.6%*
Frequency	8.7%*	4.2%*
Hesitancy	6.5%*	18.8%*
Urgency	6.5%*	10.4%*
Post-void dribbling	6.5%*	10.4%*
Blood pressure changes during treatment	6.5%*	2.1%*
Hospitalization in general related to the treatment	6.5%	0
Transient erectile dysfunction	4.3%*	12.5%*
Urinary tract infection	4.3%	8.3%
Complete loss of ejaculate	4.3%*	2.1%*
Bladder diverticuli	2.2%*	2.1%*
Weak stream	2.2%*	2.1%*
Erectile dysfunction	2.2%	0
Epididymitis	2.2%*	0
Prostatitis	2.2%	0
Nocturia	0	6.3%*
Urethral stricture	0	2.1%*
Rectal Fistula	†	†

*†Although not observed in clinical studies, isolated incidences of rectal fistula have been reported to Urologix, Inc. following product commercialization. It is believed that the incidence of this serious complication can be minimized through careful patient selection and strict adherence to the treatment instructions described in these instructions for use.*

## **Clinical Summary**

### **Original Data**

Follow-up on patients treated with the Targis System demonstrated that this device is associated with significant improvements in BPH symptoms and urine flow rates. The multiple U.S. clinical studies, which include 152 patients at 6 month follow-up, show that 79% of the Targis System treated patients experienced symptom improvement greater than 25% and that 59% experienced improvement greater than 50%. The mean improvement in AUA Symptom Score was 51%. With regard to uroflowmetry, 66% of the patients demonstrated improvements in peak flow rate of greater than 25%. The mean change in peak flow rate was 4.1 mL/s, a 53% increase over baseline.

In a randomized and blinded study, patients who received an active treatment exhibited significantly greater improvements in symptom score than sham treated patients ( $p=0.011$ ). Patients who received an active treatment also exhibited significantly greater improvements in peak flow than sham treated patients ( $p=0.002$ ).

One hundred seven patients have matched data on AUA Symptom Score from baseline to one year follow-up. The mean symptom improvement in this patient group was 10.2 points (51%). Eighty-nine patients have matched data on peak flow from baseline to one year follow-up. Mean peak flow improvement in this patient group was 3.8 mL/s (49%). Significant improvements were seen in additional measured parameters of Quality of Life, Symptom Problem Index (SPI) and the BPH Impact Index (BII). All improvements remained stable through one year follow-up. These improvements are consistent with additional data collected from international studies on over 111 patients at one year follow-up.

### 28.5 minute vs. 60 minute study data

A randomized study comparing a 28.5 minute treatment to a 60 minute treatment was conducted, enrolling 48 and 46 patients respectively. The following table summarizes the 6-month results of 44 patients followed under the Express protocol (28.5 min.) and 39 patients followed under the standard protocol (60 min.). Follow-up at 6 months indicate that both of the treatment groups demonstrated significant improvement from baseline ( $p\text{-value} \leq 0.002$  in all cases) in their AUA Symptom Score, Peak Flow Rate and Quality of Life. The results are shown as mean values.

At six months, the difference in the change in values for the AUA Symptom Score and the QoL scores between the 60 minute and 28.5 minute treatments were statistically significant ( $p\text{-value} < .002$ ). Both the 28.5 and 60 minute treatments are effective and clinically relevant treatment options.

Outcome Measurement	60 minute results	28.5 minute results
Pre-treatment AUA Symptom Score	21.0	22.1
AUA Symptom Score at 6 months	8.0	12.5
Pre-treatment Peak Flow Rate	8.7 ml./sec	8.7 ml./sec
Peak Flow Rate at 6 months	13.7 ml./sec	11.1 ml./sec
Pre-treatment Quality of Life	4.1	4.1
Quality of Life at 6 months	1.4	2.4
Alternative Surgical Treatment at 6 months	2.2%	0%

The long term (12 month) effectiveness of the 28.5 minute treatment has not yet been established. This data will be provided when available. From the current data available for the Targis clinical investigations, it is possible to identify any characteristics that are associated with a more favorable response.

The physician should give consideration to both the difference in effectiveness and adverse events in determining the most appropriate treatment time for each patient based on the patient's age, medical condition, and ability to tolerate the procedure.

### Information for Patients

Physicians should inform patients that an inherent risk of complications is associated with the Targis procedure (refer to Adverse Events and Complications). Physicians should inform patients that loss of ejaculation may occur as a result of the Targis procedure and thus should be considered by men who may wish to have further offspring. Physicians should inform patients that the volume of ejaculate may be decreased in some men who undergo the Targis procedure. Temporary acute urinary retention, temporary incontinence, minimal bleeding, pain or urination and intercourse and urinary tract infection may be associated with the Targis procedure. The patient should be informed that a small risk of urethral stricture may result from the Targis procedure requiring further intervention (refer to Adverse Events and Complications). Patients may likely be catheterized for a 2 to 5 day (median 3 day) period following the Targis procedure. Patients may be prescribed anti-inflammatory and antibiotic medications for a period following the Targis procedure. Patient should be informed that they may experience discomfort during the procedure that may require the use of analgesics or sedatives to deliver an effective treatment.

### Product Description

The Targis System utilizes proprietary microwave technology to deliver thermal energy into the anterior and lateral portions of the prostate preferentially and within the axis of the MDS antenna. This allows the Targis System to deliver energy continuously, with minimal concern of treatment-limiting shutdowns from rectal and urethral alarms. Thus, the Targis System can selectively generate and maintain peak intraprostatic tissue temperature levels of  $\geq 65^{\circ}\text{C}$  and mean intraprostatic tissue temperature levels of  $\geq 50^{\circ}\text{C}$  with

minimal risk of damage to adjacent structures. This allows the Targis System to overcome the heat sink effect of the prostatic blood flow resulting in necrosis of a large volume of diseased hyperplastic tissues.

The Procedure Kit is composed of the following individual components:

- Microwave Delivery System 3.0-5.0 (MDS)*
- Rectal Thermosensing Unit (RTU)*
- Coolant Bag*

The procedure kit is designed to be used as a system with the control unit and is intended for the treatment of symptomatic and obstructive Benign Prostatic Hyperplasia (BPH) and its associated voiding difficulties. All components must be in place with the Control Unit to begin a Targis procedure. The Targis System is a non-surgical device intended to relieve symptoms associated with BPH and is indicated for men with prostatic urethra lengths of 3.0 to 5.0 cm, measured from the bladder neck to the verumontanum. For complete and detailed instructions, refer to the Targis System User Manual.

**MDS**

The MDS is a catheter-based system that includes a fiber optic temperature sensor, microwave antenna and cable, coolant channels and connectors, urine drainage channel and a distal balloon for placement. The MDS is designed to deliver microwave energy to the target prostatic tissue, while at the same time cooling and protecting the urethra. The fiber optic sensor in the MDS monitors the urethral temperature and is used to determine the amount of energy delivered during a procedure. In the event that MDS temperature rises above 44.5°C, the Control Unit will discontinue microwave energy delivery to the MDS. For the Targis procedure, the MDS is placed in the patient’s urethra with the tip and balloon in the bladder and it is anchored into place with the 10 cc balloon. The MDS is oriented with the coolant tubing in the anterior direction. Microwave energy is transmitted from the Control Unit to the MDS antenna and directed into the prostate. The microwave energy generates heat in the prostate that causes tissue necrosis, which, when resolved can improve the patient’s symptoms, flow rate and quality of life associated with BPH.

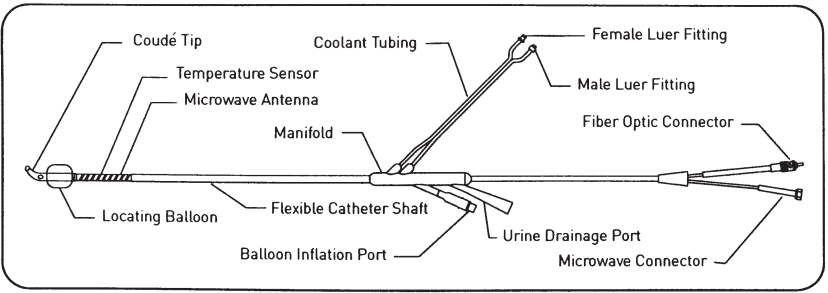

**RTU**

The RTU is a catheter-based system that incorporates a compliant balloon and temperature sensors used to monitor the patient’s rectal temperature during a Targis procedure. The RTU is placed in the patient’s rectum prior to a Targis procedure and left in place for the duration of the procedure. In the event that rectal temperatures are raised above 42.5°C, the RTU will signal the Control Unit to discontinue microwave energy delivery to the MDS. The RTU can be provided as a single use disposable device or provided in a configuration that will facilitate the cleaning and disinfection for multiple (up to 30) treatments. Refer to the Targis System User Manual for more detailed information for the use of the Targis System RTU.

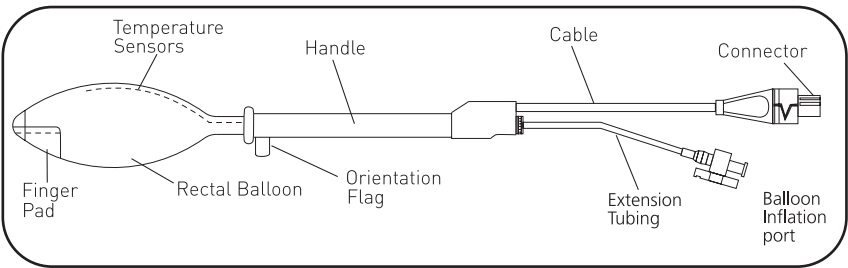

## Coolant Bag

The Coolant Bag is used as a reservoir for sterile water, which, during treatment is chilled and circulated through the MDS by the Control Unit to protect the urethra from heat generated by the MDS. The Coolant Bag is comprised of three (3) main subassemblies: coolant reservoir, sensor module and tubing with connectors. The coolant reservoir is a polymer bag that is filled with sterile water. The coolant reservoir mates with the chill plate of the Control Unit to remove heat generated by the MDS during the Targis procedure. The sensor module pressure and temperature windows mate with the corresponding measurement devices on the Control Unit. The sensor module works in communication with the Control Unit to allow pressure and temperature to be monitored during the Targis procedure. The Control Unit uses this information to monitor these parameters during the entire Targis procedure. The inlet and outlet tubing connectors mate with the connectors of the MDS to establish a closed loop coolant system involving the Coolant Bag and the MDS.

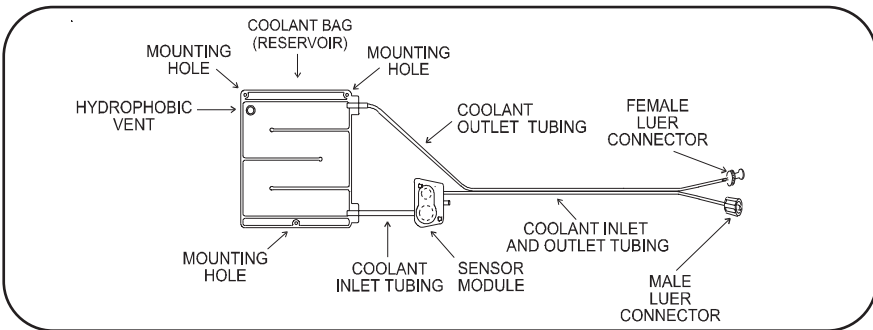

## Control Unit

The Control Unit is used to provide and control energy generation and safety for the Targis procedure. The Control Unit includes a computer, microwave energy source, coolant system, fiber optic temperature monitoring system and software. These systems are integrated to precisely and continuously monitor all

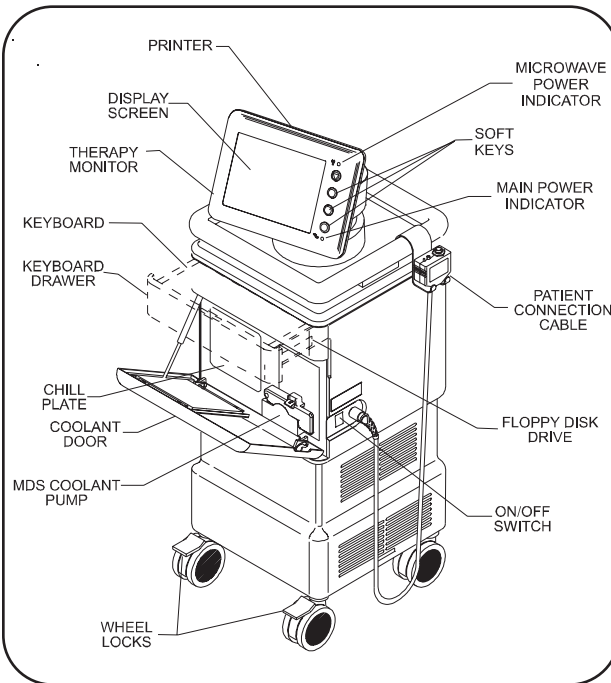

aspects of a Targis procedure including energy generation and delivery, coolant temperature, and the use interface to provide safety shutdowns when procedural and patient safety issues are detected. The Control Unit also maintains a procedural file on the parameters of treatment for an individual patient and procedure.

## Accessories

Several accessories accompany the Targis System. They include:

- *Targis System Users Manual*
- *Control Unit Dust Cover*
- *Patient Comfort Kit containing 2 Knee Cushions and an MDS Holder*
- *Patient Cable Holder*
- *An optional Transport Kit containing a Trolley, Protective Cover, and Electrical Safety Tester*

## REFER TO THE UROLOGIX USER MANUAL FOR SPECIFIC AND COMPLETE INSTRUCTIONS FOR THE OPERATION STEPS AND PROTOCOL.

## ENSURE PATIENT HAS RECEIVED AN EFFECTIVE ENEMA WITHIN 2 HOURS PRIOR TO INITIATION OF TREATMENT

### References

1. Paul D. Miller, Keith Parsons, Ernest Ramsey, Transurethral Microwave Thermoablation (TUMT) for Benign Prostatic Hyperplasia Using a New Device (T3), Presented at the 90th Annual Meeting of the AUA, Las Vegas, NV April, 1995.
2. Ramsey E.W., Miler P.D., Parsons K., Transurethral Microwave Thermoablation in the Treatment of Benign Prostatic Hyperplasia: Results obtained With the Urologix T3 Device. *World Journal of Urology* (1998) 16.
3. Larson T.R., Bostwick D.G., Corica A., Temperature Correlated Histopathologic Changes Following Microwave Thermoablation of Obstructive Tissue in Patients with Benign Prostatic Hyperplasia. *Urology*. 1996;47 (4): 463-469.
4. Larson T.R., Blute M.L., Tri J.L., Whitlock S.V. Contrasting Heating Patterns and efficacy of the Prostatron and Targis Microwave Antennae for Thermal Treatment of Benign Prostatic Hyperplasia. *Urology* 51 (6), 1998.
5. Djavan B., Larson T.R., Blute M.L., Marberger M. Transurethral Microwave Thermoablation: What Role Should it Play Versus Medical Management in the Treatment of Benign Prostatic Hyperplasia? *Urology* 52 (6), 1998.

The Targis System was formerly known as the T3® System during its development and clinical trials.

### How Supplied

All components of the Procedure Kit are intended for one time use only. DO NOT resterilize and/or reuse them as this will likely result in compromised device performance and increased risk of injury or infection to a patient and treating staff. The Procedure Kit components are supplied in sterile double barrier packaging that has been exposed to ethylene oxide. The Procedure Kit and components are placed in shelf boxes with tamper proof labels. DO NOT USE COMPONENTS THAT HAVE EVIDENCE OF A COMPROMISED PACKAGE OR DAMAGE. Store in ambient conditions between 59-95°F (15-35°C).

### Restricted Devices

The Procedure Kit, its components and the Control Unit are intended for urological use only in the treatment of patients suffering voiding difficulties secondary to BPH. Candidates for Targis procedure require careful consideration. The Procedure Kit components must not be used with any other system.

Only those physicians who have been thoroughly trained on the operation of the Targis System and the Targis procedure should deliver the Targis procedure.

### Warranty and Limitations

Urologix, Inc. warrants that each component of this device has been manufactured, packaged and tested with reasonable care and will be free from defects in workmanship and material. Urologix will not be liable for any incidental, special, or consequential loss, damage or expense direct or indirect, from the use of its product. Urologix' sole obligation shall be to repair, replace, at its option, any device that we feel was defective at time of shipment if notice thereof is received within one year of shipment. Buyer assumes all liability, whether arising on warranty, contract, negligence, compliance with all local laws and regulations which govern the use and sale of this device, or otherwise for damage resulting from the handling, possession, use, or misuse of the product. Because Urologix has no control over the operation, inspection, maintenance, or use of its products after sale and has no control over the selection of patients, THIS WARRANTY IS EXPRESSLY IN LIEU OF ANY OTHER EXPRESSED OR IMPLIED WARRANTY OF MERCHANTABILITY OR FITNESS FOR ANY PARTICULAR PURPOSE, AND OF ANY OTHER OBLIGATION ON THE PART OF THE SELLER. If the user is located outside the United States, Urologix invokes all oral or written expressed or implied warranty, limitations legally permissible in that jurisdiction. The remedies set forth in the above Warranty and Limitations shall be the exclusive remedy available to any person. No agent, employee or representative of Urologix has any authority to change any of the foregoing or assume or bind Urologix to any additional liability or responsibility in connection with this device.



Urologix, Inc.  
14405 21<sup>st</sup> Avenue North  
Minneapolis, Minnesota, 55447 USA  
Tel: 763-475-1400  
Fax: 763-475-1443  
Toll Free: 800-475-1403  
www.urologix.com

EU Authorized Representative:  
MDCI Ltd  
Arundel House  
1 Liverpool Gardens  
Worthing, West Sussex BN11 1SL, UK